

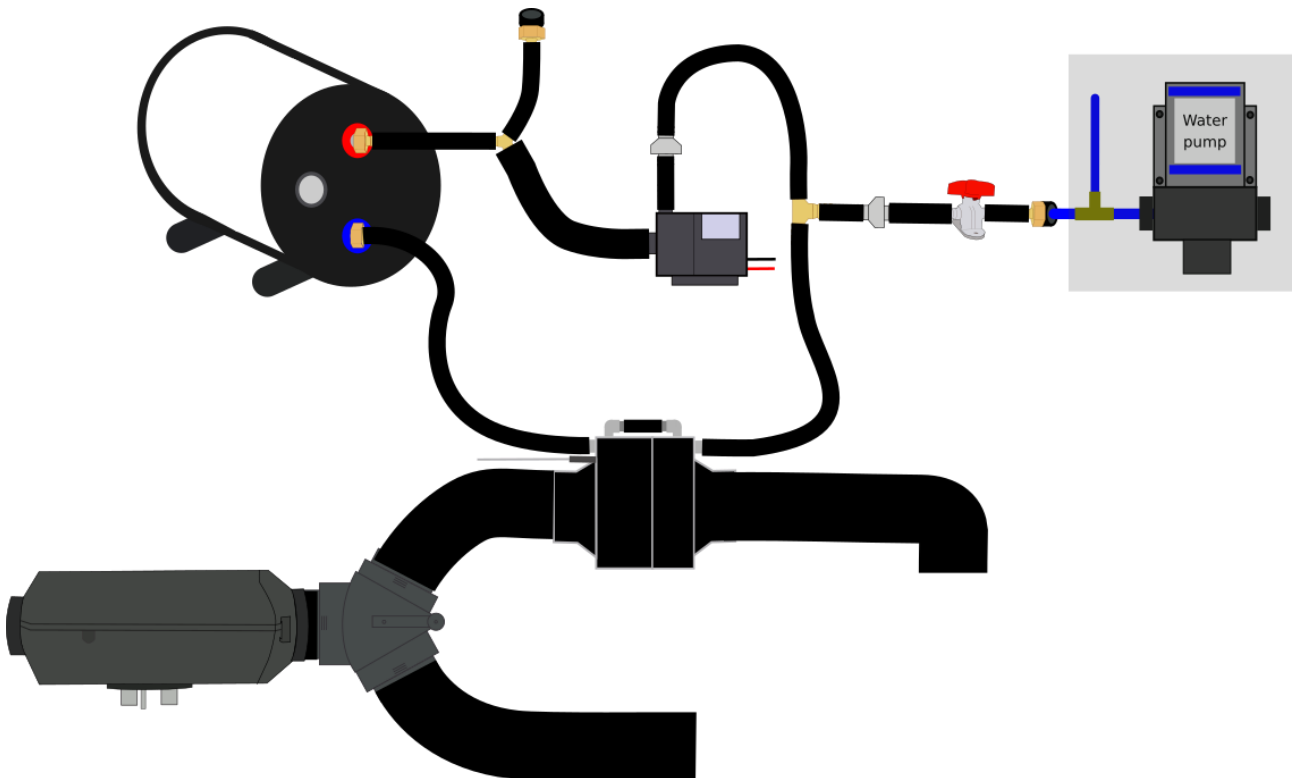

# BOBIL VANS AIR HYBRID WATER HEATER & CALORIFIER KIT

## INSTALLATION INSTRUCTIONS





## Important Safety Instructions! Please save these instructions!

This manual contains important safety, installation, and operating instructions for the Bobil Air Hybrid water heater & calorifier kit.

The manufacturer accepts no liability for damage by:

- Incorrect assembly.
- Damage resulting from mechanical influences or excess voltage.
- Modification or tampering with the unit without expressed permission from the manufacturer.
- Used for purposes other than described in this manual.

### General safety

- Firmly secure all cables and hoses.
- In the event of product failure, do not attempt to repair the water heater. Inadequate repairs may cause serious injury.
- Electrical devices are not toys - keep away from children.
- Disconnect the product from the battery and mains power each time before cleaning or maintaining the heater.
- This product is for 12V battery banks and 230V AC circuits only. Make sure your voltage specification is within the input voltage range expressed.
- Install and store the product in a dry and cool place.
- Keep electronics away from liquids!
- Do not use the product if physically damaged or with visibly perished hoses.

### Installation

- Ensure secure location where it cannot tip or fall.
- If necessary, verify installation with a qualified electrician or installer.
- Do not use a water pump with a pressure exceeding 20psi.
- Lay cables so they cannot be damaged or be a tripping hazard.
- Do not operate in salty, wet, or damp environments; in the vicinity of corrosive fumes; in the vicinity of combustible material; in areas with risks of explosions.
- Ensure proper cable sizing for currents generated.
- Over-current protection devices should be on the positive line.

Due to the nature of ways the Bobil Hybrid systems can be fitted, we cannot account for all instal variations and eventualities in this instruction manual. If you install your system in a way which deviates from these instructions without contacting us beforehand, then we cannot accept fault for any issues that might occur due to incorrect assembly or use, and as such, broken parts would not be covered under warranty.

If you have any questions about your installation, please email us at [info@bobilvans.co.uk](mailto:info@bobilvans.co.uk)



## What comes in the box?

Please unpack all bags and boxes and ensure you have everything before beginning installation.

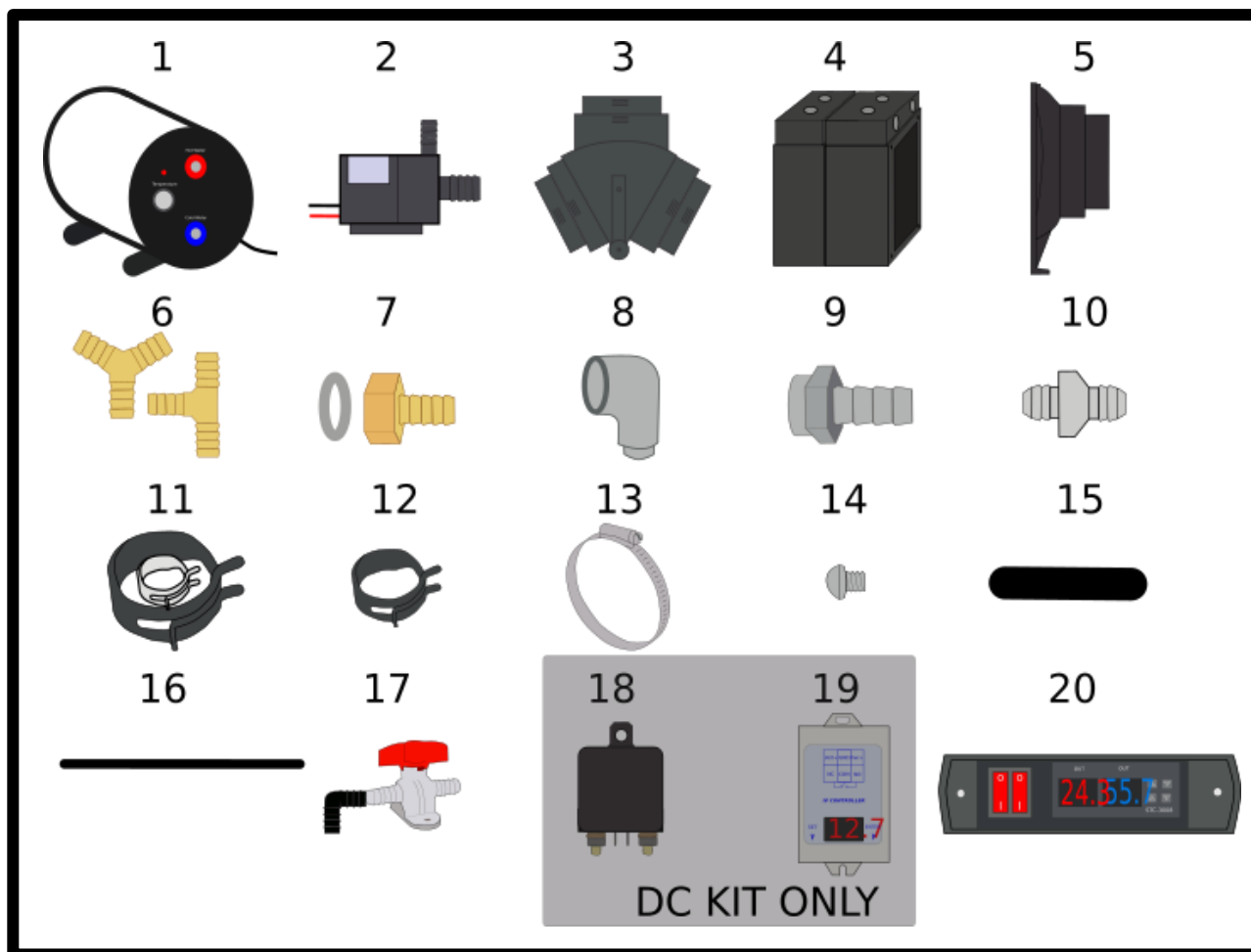

1. 10L Hybrid Tank	11. Hose Clamps (x2 big black, x1 silver, x1 tiny black)
2. Circulation Pump	12. Small Hose Clamps (x27)
3. Diverter Valve + Flap	13. Jubilee Clips (x5)
4. Heat Exchanger Assembly	14. Screws (x8)
5. Ducting Adaptors + Gaskets (x2)	15. 10mm ID hose (0.25m)
6. Y and T Splitter	16. 8mm ID hose (2m)
7. ½" Barbed fittings & Washers (x4)	17. Drain Valve (x3) & Elbow (x2)
8. 90 Degree Elbow (x4)	18. High Current Relay (DC/Dual Voltage ONLY)
9. Heat Exchanger Barbed Fittings (x6)	19. Solaris Voltage Controller (DC/Dual Voltage)
10. One Way Valve (x2)	20. STC 3008 Controller

If you ordered a remote cable, you will also receive this along with a small bag containing a tiny screw, a bracket and a knob.



## Preparing your installation area

The tank should be installed in a cupboard or locker which is clean, dry, ventilated, accessible and free of explosive gases or vapour such as those given off by charging batteries. The heat exchangers can be installed remotely from the tank, even under the vehicle. If they are mounted under the vehicle the units should be protected from road debris and hose should be secured where they won't be damaged by being passed through the floor of the van.

Space should be left in front of the heater so the hoses are not kinked and the temperature dial is accessible.

Scan this code with your phone camera to watch an installation video of the Bobil Air Hybrid.

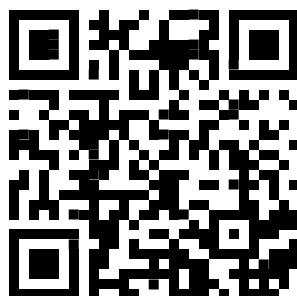

Along with the above kit, to install the Bobil Air Hybrid Kit you will need the following tools:

- Pliers (to fit hose clamps)
- Adjustable Spanner/Spanner Set
- Drill and 4mm drill bit
- Scissors to cut silicone hose
- Small flat heat & phillips screwdriver
- Socket set

## Thank you for buying our products!

Small businesses like ours only exist because of the support of our customers. We appreciate you purchasing from us, and hope that you have a great experience.

If you have any installation questions or queries then just get in touch, we're here to help. Contact us at [info@bobilvans.co.uk](mailto:info@bobilvans.co.uk) or on the phone at +44 1275 261074



1. **TANK CONNECTIONS:** Screw the barbed fittings and overpressure valve onto the tank, using the supplied washers to seal. Hand tighten the brass fittings, then apply a ¼ turn with a spanner. **Do not overtighten.**

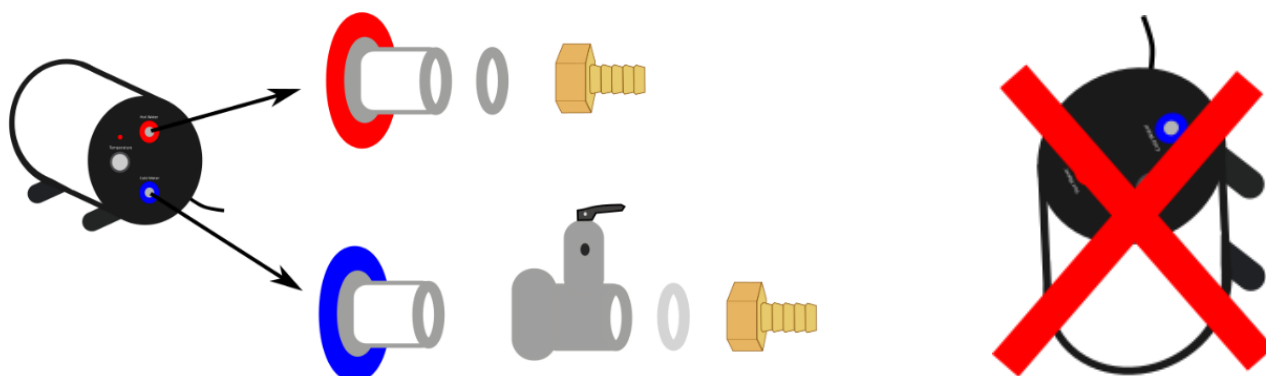

**The tank must be mounted horizontally as shown**

2. **PUMP ASSEMBLY:** Assemble the pump assembly using hose clamps as shown. The larger T piece goes onto the larger 10mm ID pipe. Note the silver clip on the outlet of the pump.

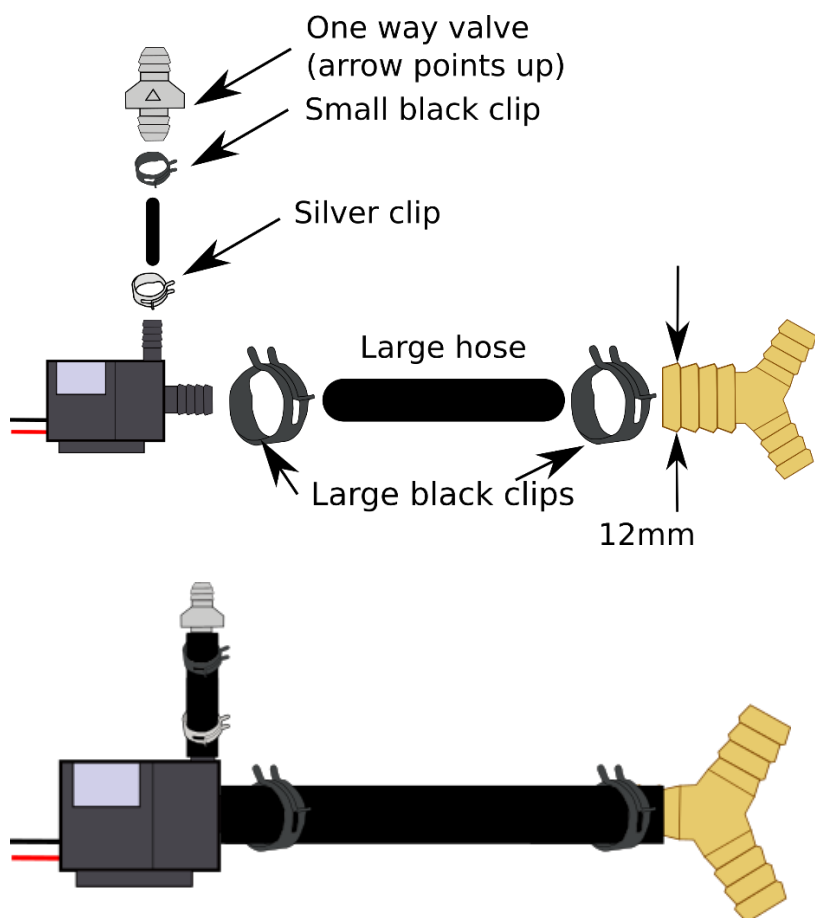

3. **INLET ISOLATION HOSE:** Cut 2 x 5cm lengths of the 8mm ID silicone hose and assemble this with the T fitting, one-way valve, isolation valve and hose clamps. Ensure the one-way valve points towards the fitting. This creates an isolation valve for the cold water to the whole system.

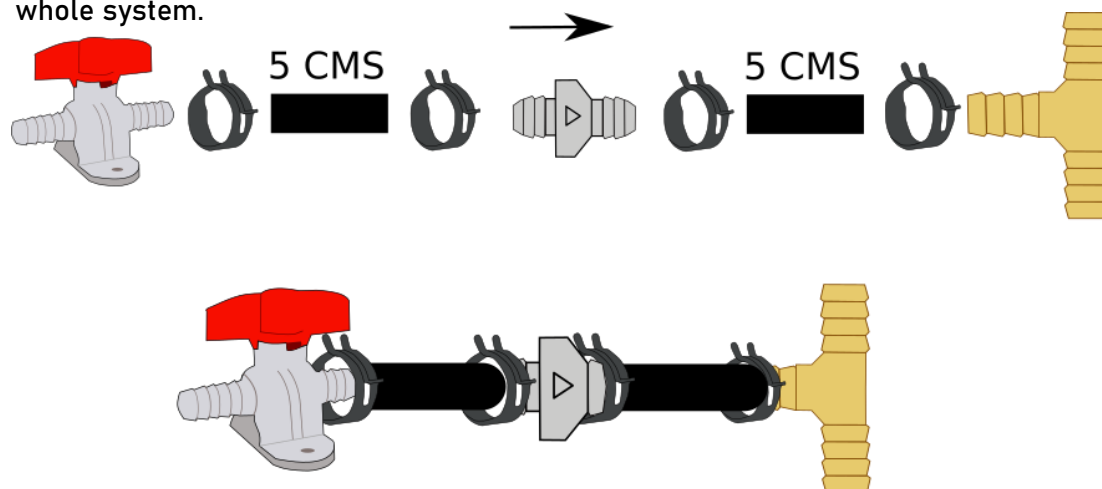

4. **HEAT EXCHANGER ASSEMBLY:** Remove the 4 red plastic blanking plugs and 2 metal blanking plugs. Assemble heat exchangers as shown, adding the metal blanking plug into the spare port on the exchanger. **Do not overtighten the fittings. Hand tighten only.** Add a small piece of the 8mm ID silicone hose to connect the 2 top ports together.

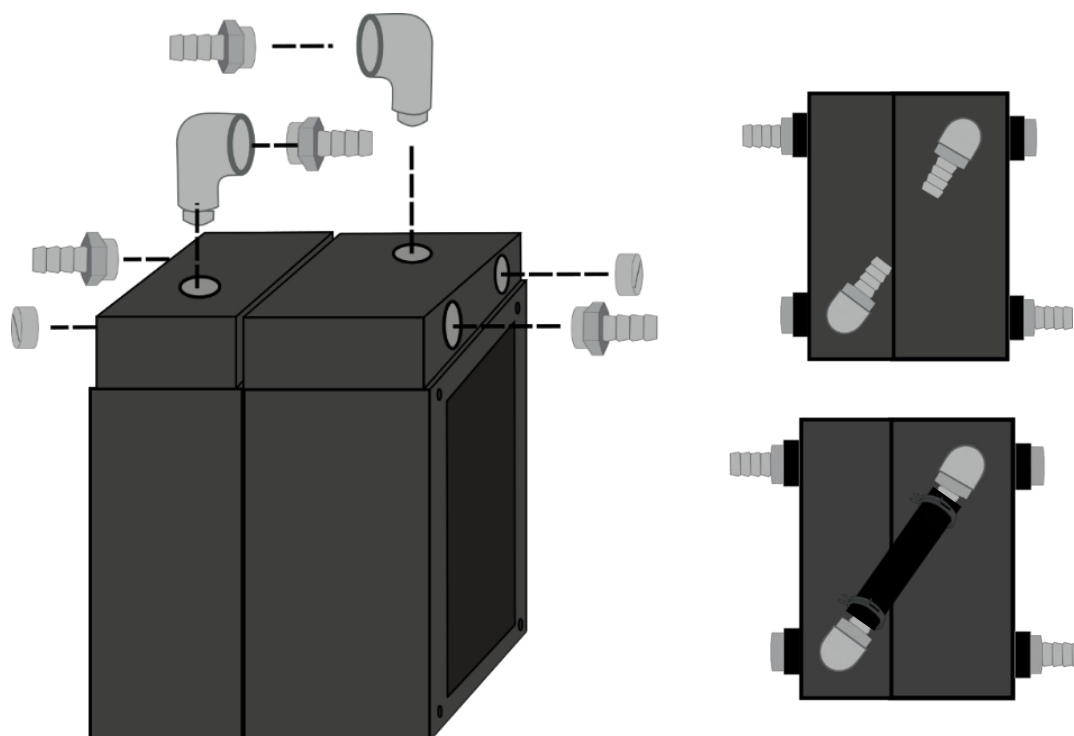

*Optional: If you don't have space above the heat exchanger for the cross pipe, you can use the blanked off outlet and route the pipe around the side of the exchanger.*

- . **DRAIN KIT (optional):** Install the drain kit.

This is required for use in cold climates when the water in the heat exchanger is likely to freeze. If you do fit the drain kit, you must mount the exchangers on the supplied spacers to allow space underneath the unit.

Screw in the remaining elbows and barbed fittings to the drain ports. Add drain valves and black elbow fittings as shown, at a convenient place to drain the tank. You will then need to add silicone hose and hose clamps (not shown in this image for clarity).

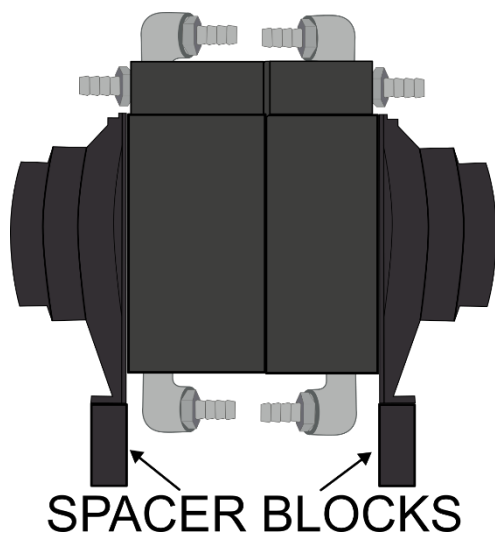

The spacer blocks click into the adaptors and allow a long screw to be fitted down through the block.

- 
5. **HEAT EXCHANGER ADAPTORS:** Drill a 4mm hole for the thermocouple in one of the heat exchanger ducting adaptors.

Assemble ducting adaptors onto heat exchangers. Ensure the adaptor with the drilled hole goes on the thicker exchanger.

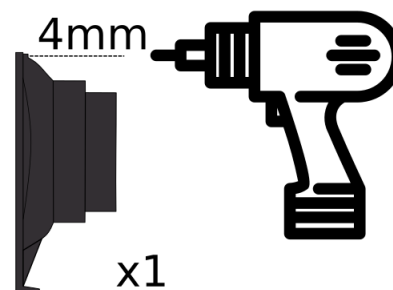

Add the rubber gaskets between the exchanger (orientation doesn't matter) and the adaptor. Fitting the screws through the adaptor and gasket before fitting to the exchanger makes this task much easier.

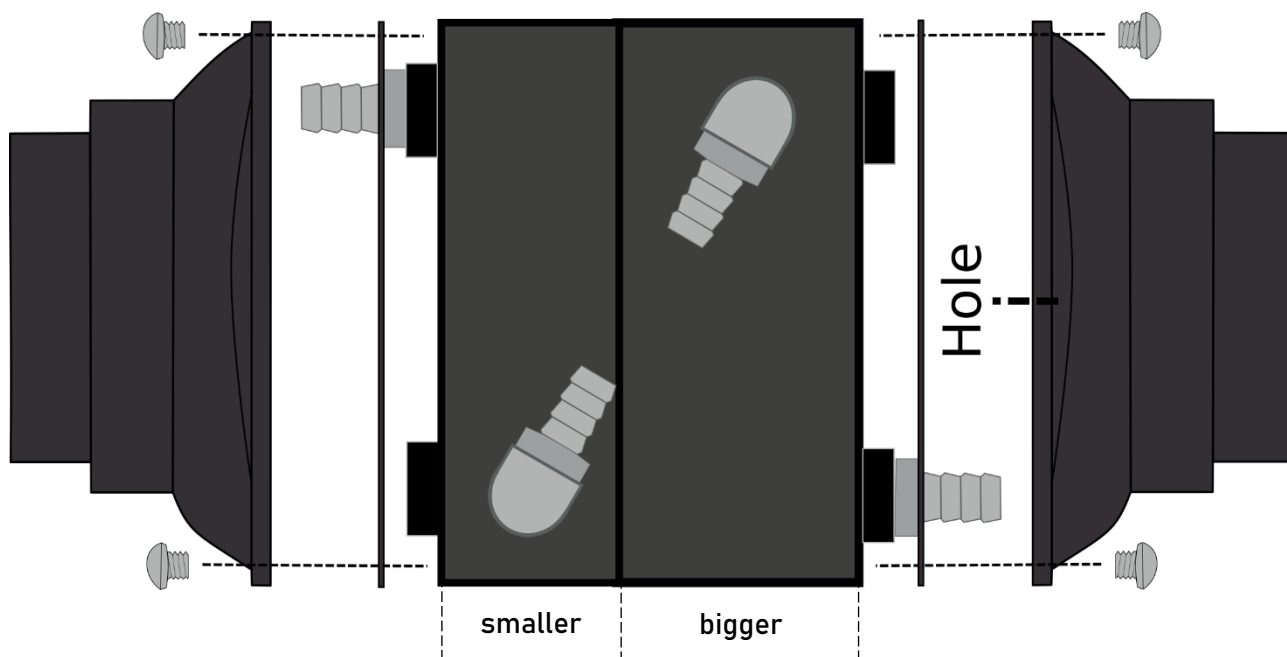

6. **DIVERTER ASSEMBLY:** Assemble the diverter by clipping together the two halves of the units with the flap in between. then clip on the arm to lock everything together. The exchanger can be situated on either branch of the diverter.

If you have purchased a remote cable you will also receive a bracket and a small screw. You will need to bend the bracket slightly to get it under the jubilee clip, and install it so that the clip is furthest away from the centre of the diverter as shown in the image.

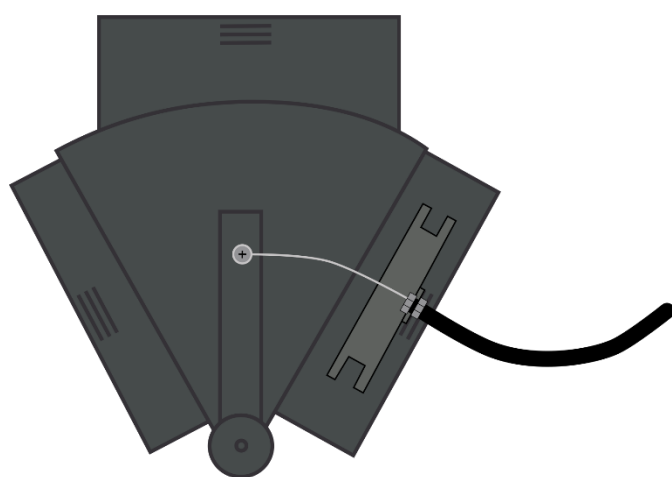

60mm & 90mm ducting

For the 60 and 90mm diverter, the bracket will go under the same jubilee clip which holds the ducting onto the diverter.

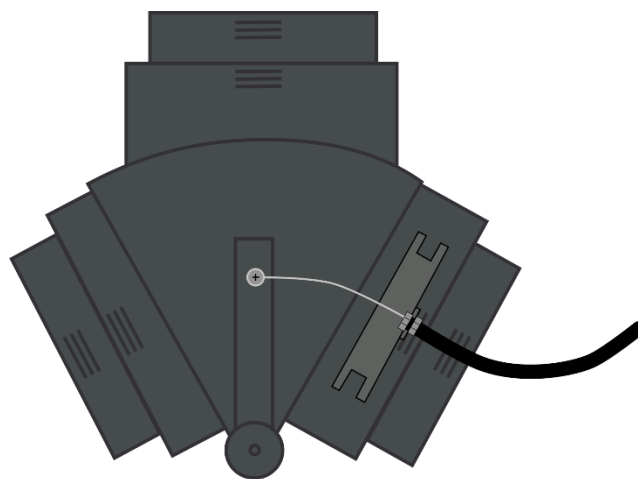

75mm ducting

For the 75mm diverter, you will also receive an extra jubilee clip which holds the bracket onto the large diverter.



Install the fixed end of the cable first by drilling a 12mm hole on the surface you want to mount your cable on. Remove one nut and feed the cable through before reattaching the nut, tightening to fix, then attaching the cable itself to the diverter bracket.

7. Screw your inlet and outlet fittings (not included) onto the remaining two threaded barbed fittings, using the sealing washer for a watertight seal.

We sell a variety of John Guest Plumbing fittings to easily fit to our Bobil Hybrid system: <https://www.bobilvans.co.uk/plumbing-fittings>



For 15mm plumbing, we'd recommend John Guest 15mm push fit to 1/2" couplers (Screwfix part number 23662)



These attach onto your inlet isolation hose assembly (from step 3) and pump assembly (from step 2). You can use some of the remaining silicone hose to attach the inlet/outlet barbs to the correct ends.

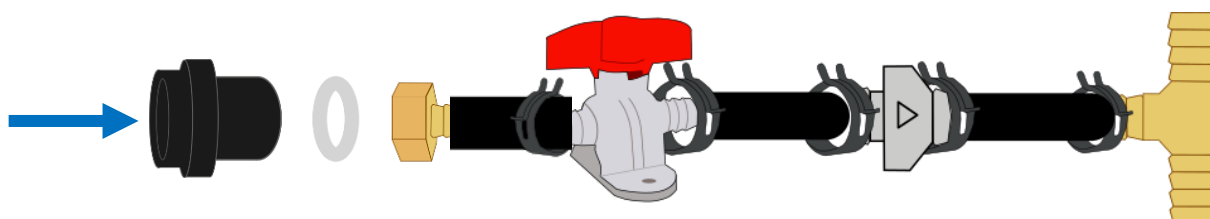

If you have flexible hose you can use a 10mm to (your hose size) straight barbed joiner and disregard the barbed connectors.



## Final Assembly

Assemble the heater kit as shown on the next page.

Ensure that hose clamps are used on every joint.

The ducting should be secured with the supplied jubilee clips, and the ducting exhaust from the heat exchangers can be used to either heat a shower room, garage or vented straight outside through the floor of the van.

Note that a length of silicone hose (0.5 metres) between the water pump and the one-way valve will act as a mini accumulator for diaphragm pumps, saving cost and space.

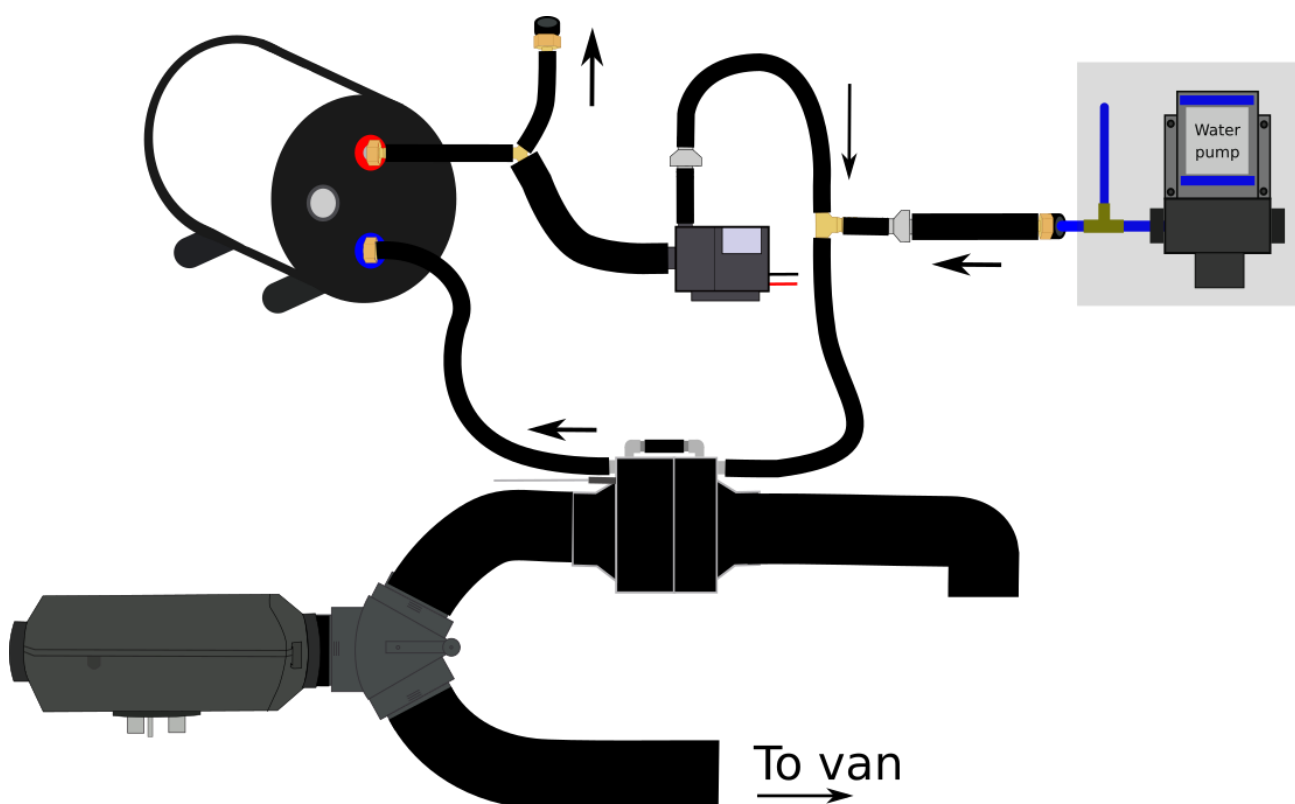

The circulation pump can be mounted vertically if preferred so water runs straight into the inlet. The hot outlet must run vertically so that any air from the tank is allowed to escape, else you may get an airlock.

**The diverter valve MUST be fitted BEFORE the heat exchanger!**

When the circulation pump stops once the water is up to temperature, water sits in the heat exchanger and reaches up to 120C. When the pressure is realised by opening a tap, this will cause rapid boiling and excessive pressure, which over time leads to premature exchanger failure.

**You must also manually divert hot air away from the heat exchanger once the water is up to temperature and the circulation pump cuts off (or turn off the diesel heater).**

The outlets of the heater should be separate, do not combine them into one outlet as this will cause heat to enter the heat exchanger from the back, leading to premature exchanger failure.

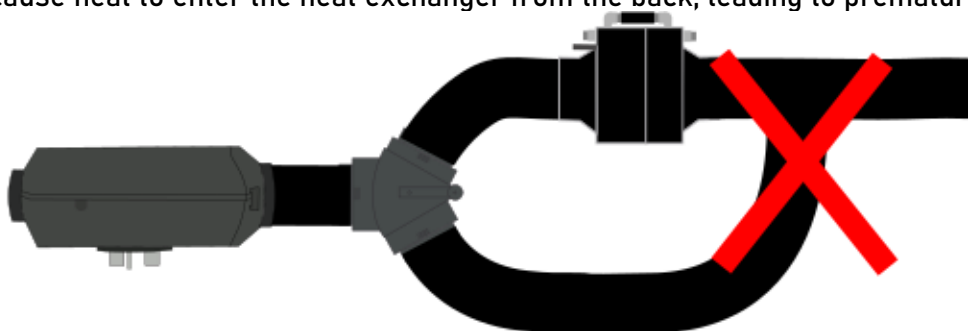

## Plumbing Layout

Here is a suggested layout for your van plumbing:

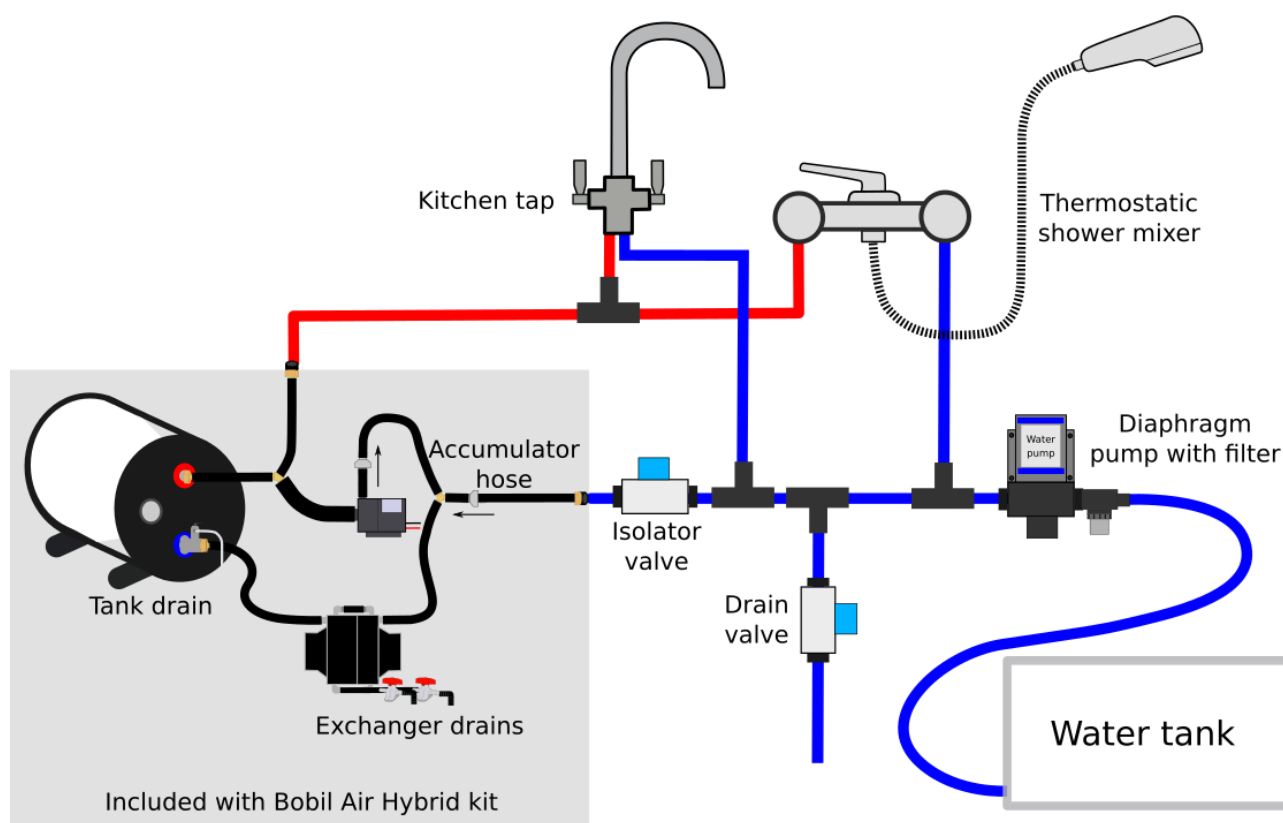

**Maximum cold water pump pressure for the Hybrid system is 20 psi.**

If your pump is higher pressure than this, please contact us for more information

Secure all units using screws. Drill holes in the van floor for the tank drain pipe and the heat exchanger drain pipe. Fit the clear drain pipe to the tank using the supplied 8mm hose clamp to secure the pipe to the fitting.



## Electrical Wiring (12V DC kit)

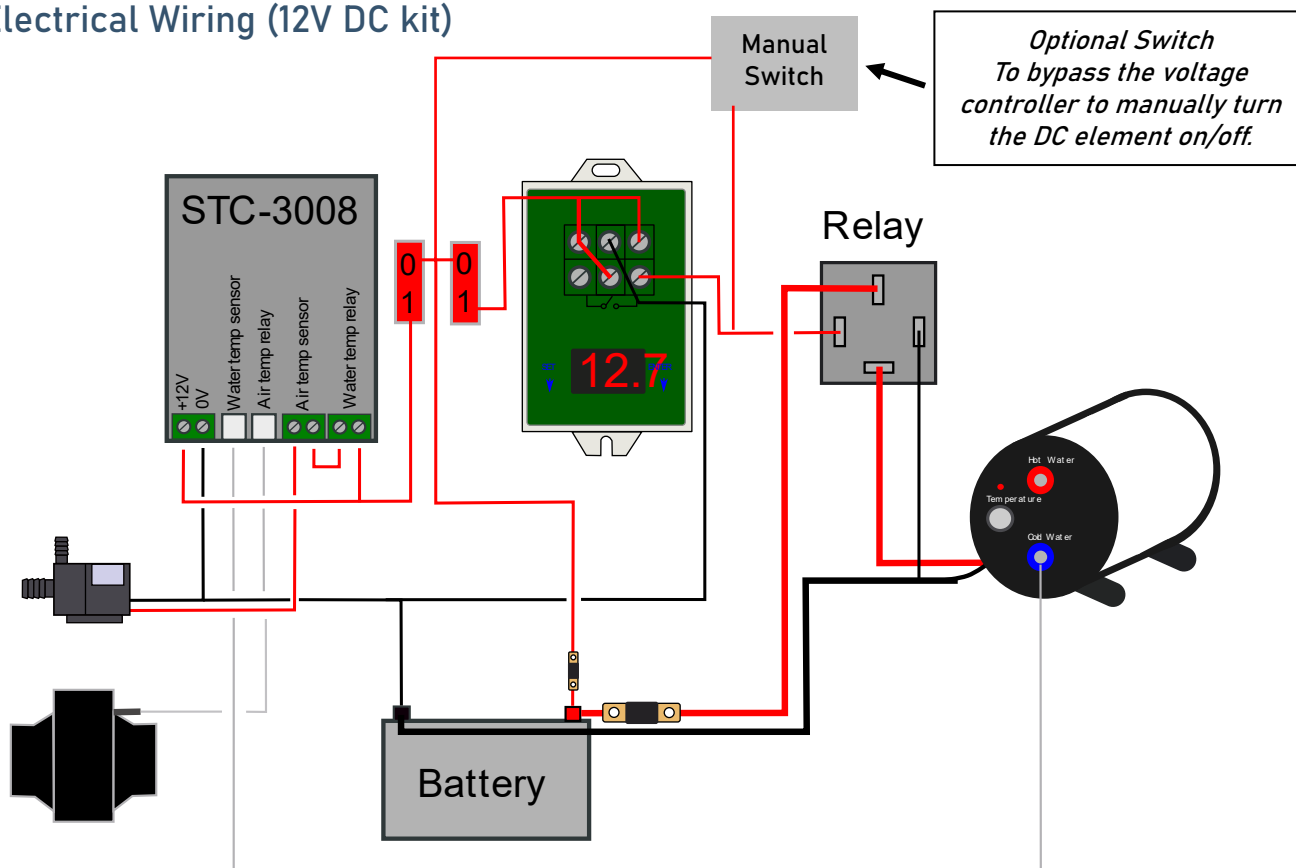

Note: The Solaris is sensing the battery voltage via the wires powering the unit. If you see a discrepancy in the sensed voltage when the heater is on, this could be because you are measuring a voltage drop somewhere in the system caused by the heater load.

This is common if you are using the same fuse box for both Solaris and heater power. If this happens, run a second (fused) sense cable directly from the battery terminal to the sense pin on the Solaris as shown here.

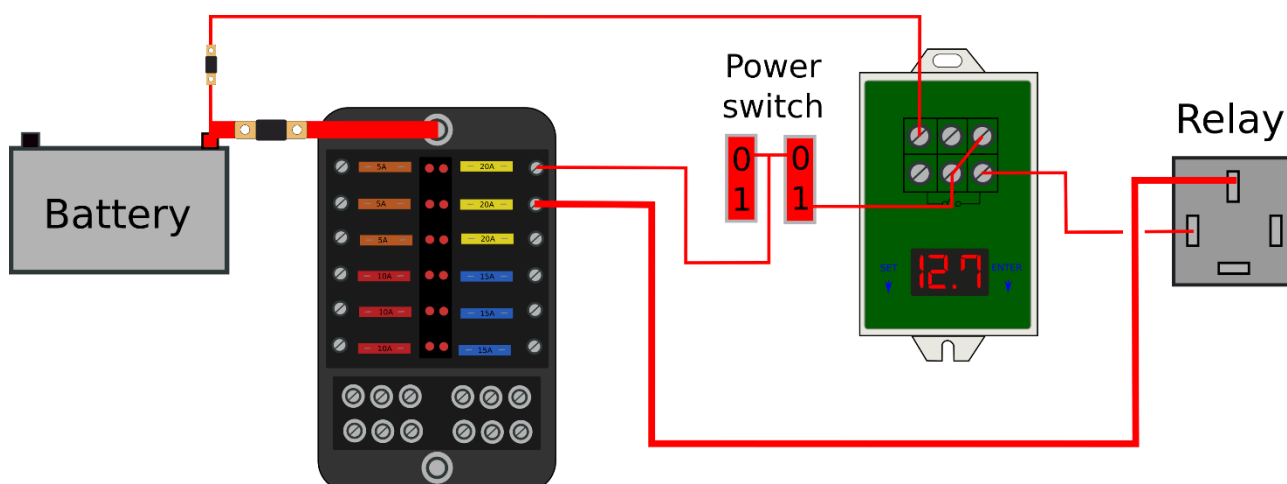

## Electrical Wiring (230V AC)

AC units come with bare wires (live, ground and neutral). It is designed to be hooked up directly to shore power (via a regular 3 pin plug, or into a shore power adaptor) or an inverter via a fused spur. Use a 5A fuse. Do not connect the 12V DC and 230V AC circuits together!

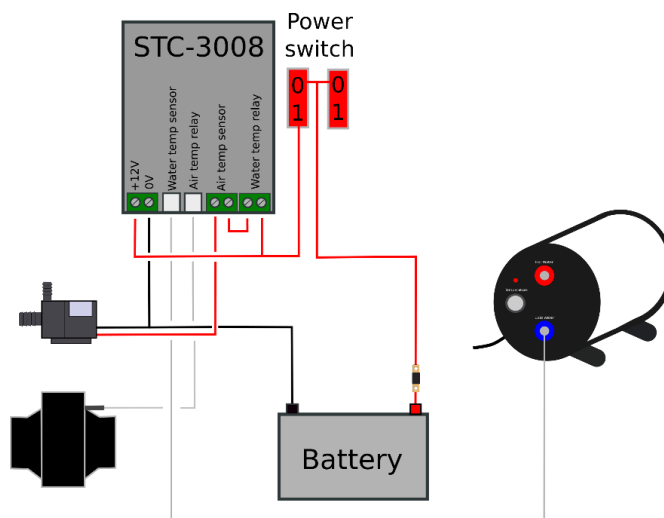

## Electrical Wiring (Dual Voltage Tank)

There are 2 elements in the dual voltage tank, the 800W AC element, and the 200W DC element.

The dual voltage tank is wired so that the dial on the front of the tank controls the temperature in the tank when being heated by the AC element, and the STC-3008 temperature controller controls the temperature when heated with the DC element.

**You must wire the DC element through the controller** else the element will stay on permanently until the internal thermal cut out permanently disables the heating. Resetting this device involves taking the tank apart so **please ensure the wiring is correct.**

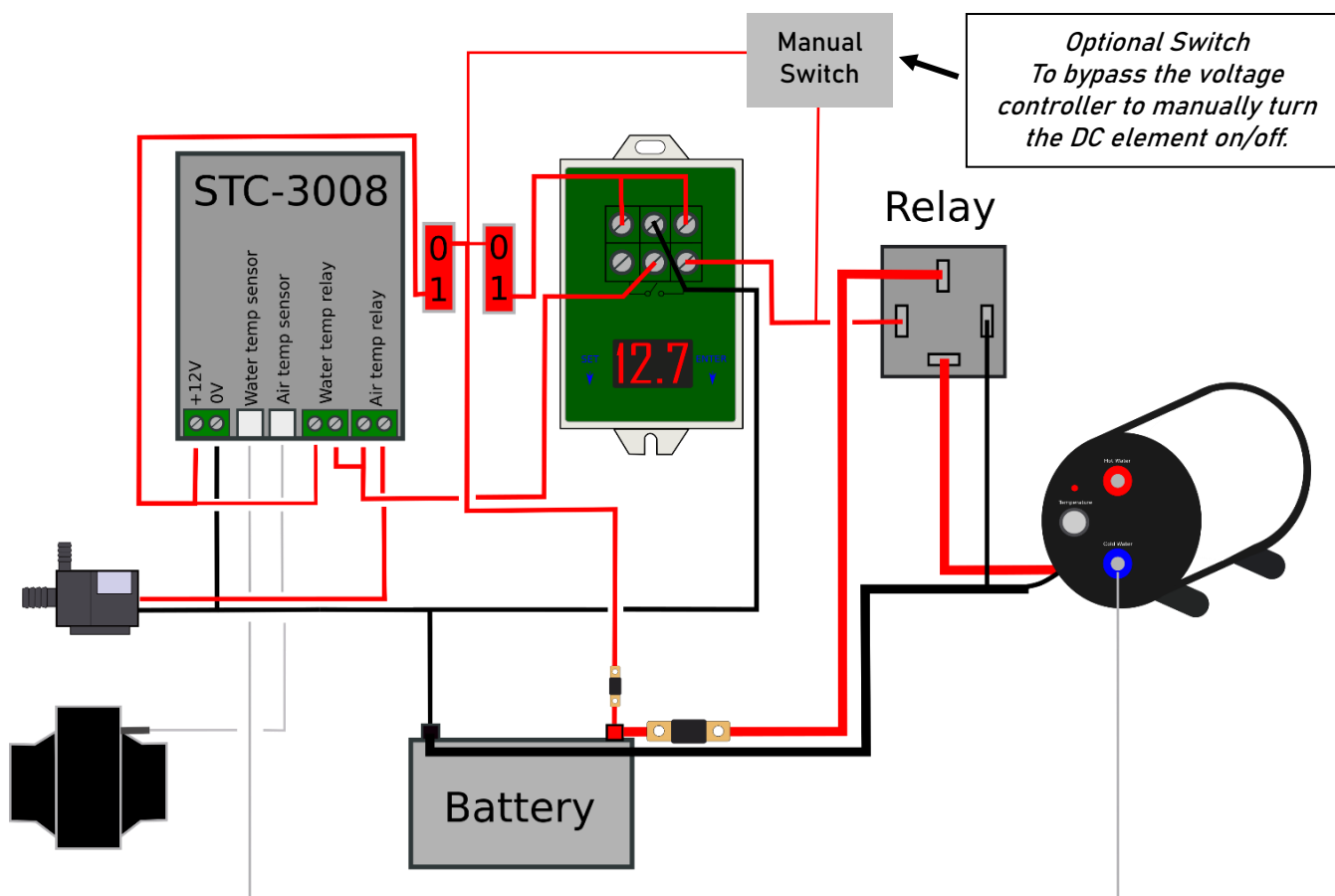



You can also wire the Solaris sense pin directly to the battery as shown on the previous page if you have a long cable run and are experiencing voltage drop.

## Temperature Sensors

In your kit, you will receive 2 temperature sensors with the Dual Temperature Controller (STC 3008).

The air temperature sensor should be clamped under the jubilee clip on the ducting run from the heater.

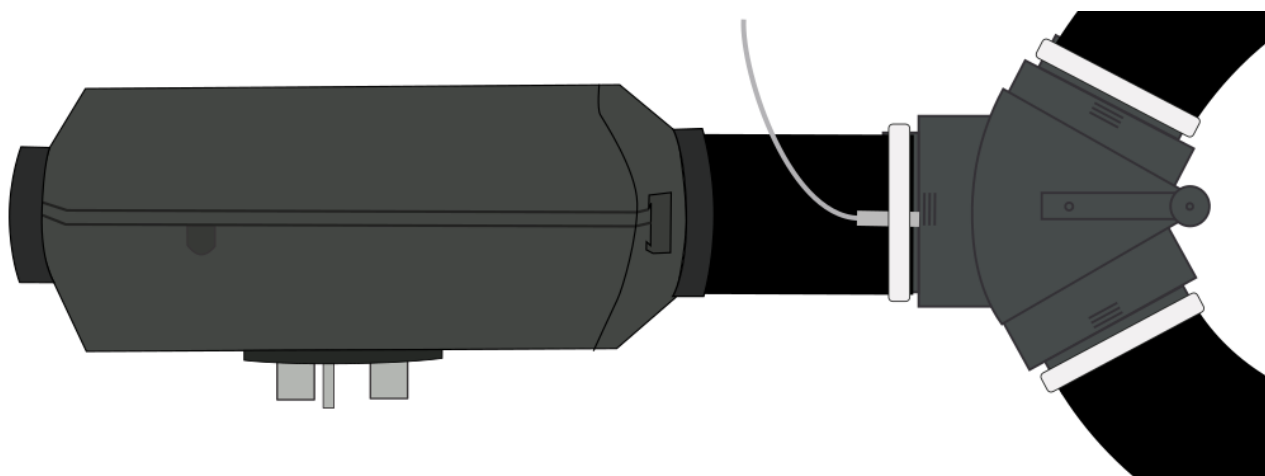

The water temperature sensor is in the tank; connect the cable from the tank directly to the controller. If this is not long enough, you can cut off the head of the 2<sup>nd</sup> temperature sensor and extend the connector on the tank.

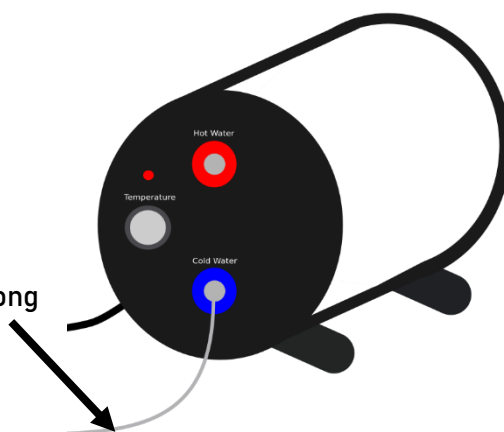

## Wire Sizing

This table gives minimum wire sizes for the heater and controllers for a given distance from the heater to the battery.

Distance	1-2M	3M	4-6M	7-8M	7-8M
Element (mm <sup>2</sup> )	2.5mm	6mm	10mm	16mm	25mm
Element (AWG)	14 AWG	10 AWG	8 AWG	6 AWG	4 AWG
Controllers (mm <sup>2</sup> )	1mm	1.5mm	2.5mm	2.5mm	4mm
Controllers (AWG)	17 AWG	16 AWG	14 AWG	14 AWG	12 AWG





Ensure that the cables are appropriately fused. We recommend a 25A fuse for the element and a 2A fuse for the controllers. The AC element (if your tank has one) should be fused at 5A.

## Programming your Pump Controller (STC 3008)

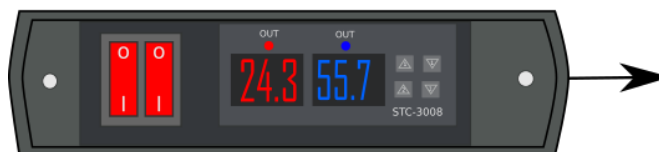
You need to set the air temperature to activate the relay at 40 degrees and deactivate it at 38 degrees, whilst the water temperature should be deactivated at 75 degrees and reactivated at 73 degrees.

To do this, hold down the relevant arrow and when it starts flashing, adjust using the up and down keys. You can adjust the air temperature values to suit your installation but do not set the maximum water temperature higher than 75 degrees.



-  Set to 40 degrees
-  Set to 38 degrees
-  Set to 73 degrees
-  Set to 75 degrees



## Voltage Controller Programming (Solaris - 12V/Dual Voltage)

For a video on programming the controller scan the code below:

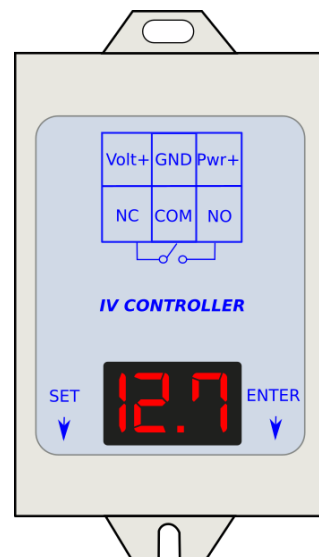

The controller will wait for the battery voltage to go above the programmed limit (V-1). When it does, it will wait for a short time delay (T-1) before switching on the relay. The relay will stay closed until the voltage drops lower than the second programmed limit (V-2), when it will start a second time delay (T-2) before switching the relay off.

We recommend that T-1 is set to a minimum of 300 seconds which will stop the relay being switched too quickly if there is not enough power to maintain the voltage. Likewise, the second time delay should always be set to '0' so the relay clicks off quickly to free up power if there are any other loads placed on the battery.

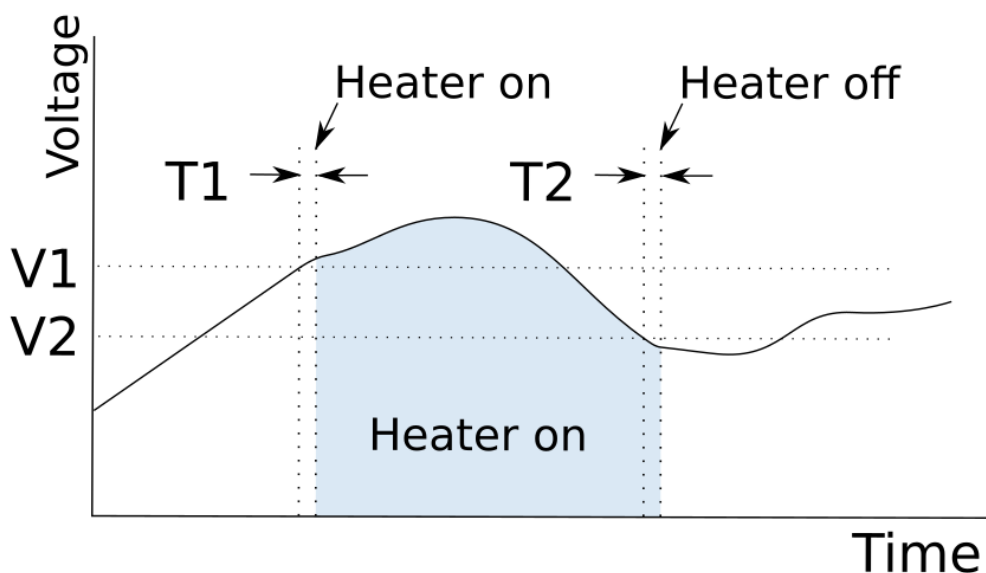

Note that for the element to stay on, you must have enough power coming in to maintain the voltage. If the element is turned on then immediately goes off, it is because the power supplies are not sufficient.





## Suggested Solaris Values

The following voltages are only suggestions, you may need to alter them according to your battery and solar set up.

Suggested values	Turn on threshold (T1)	Turn off threshold (T2)
Lead acid/AGM batteries	14.0	12.8
Lithium batteries (Summer)	13.5	12.4
Lithium batteries (Autumn-Spring)	13.8	12.7

### How to Program the Solaris

Press 'SET' to move characters  
Press 'ENTER' to change the value

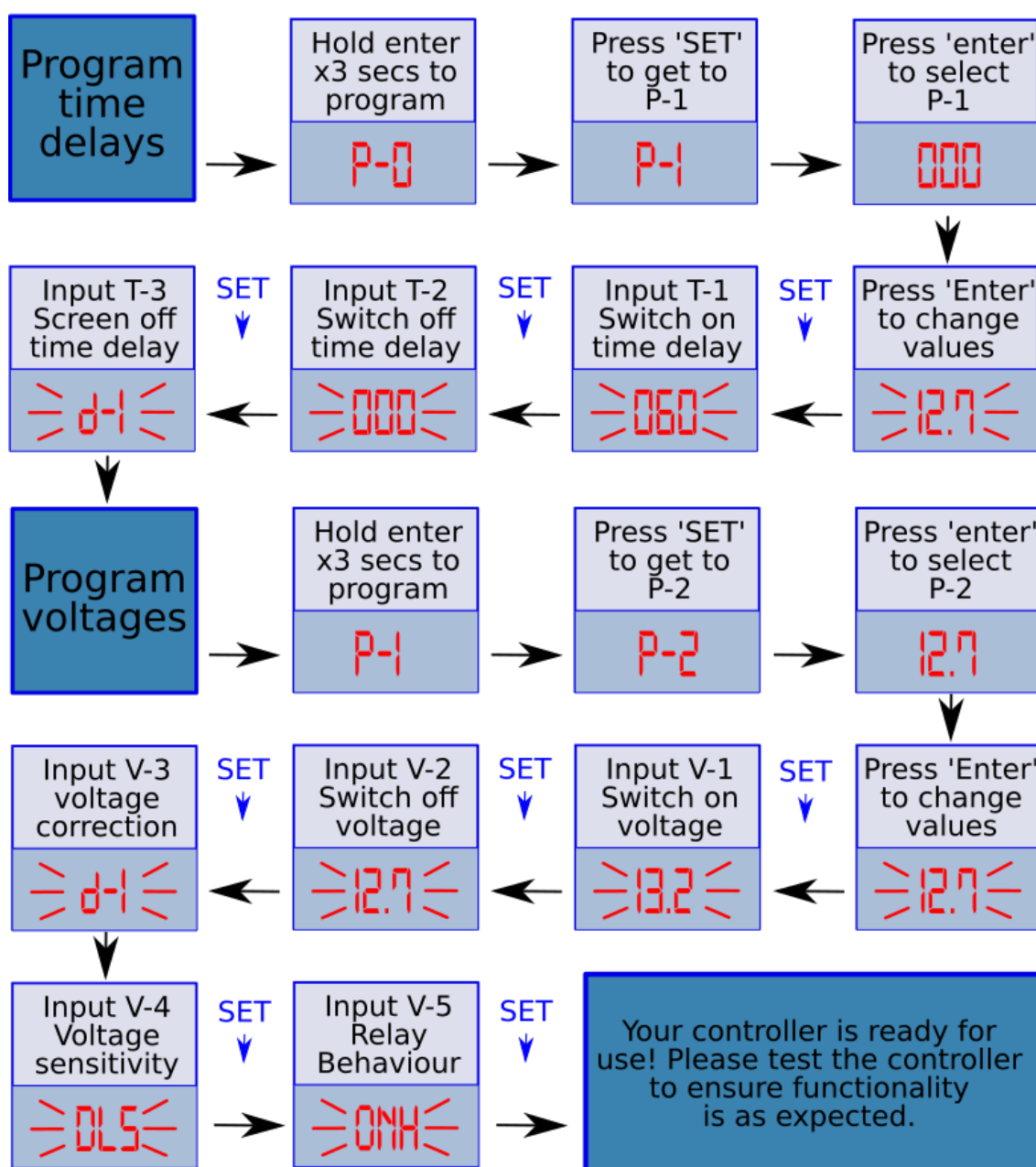



## First Start Up

To commission your system for the first time, follow these steps.

1. Close all drain valves on the heat exchanger and the tank.
2. Open sink hot tap fully.
3. Point the diverter to the heat exchanger.
4. Turn on the cold pump and open the isolator valve. You should hear water being pumped around the system and filling the tank.
5. You should see water coming out of the hot tap in 1-2 minutes depending on your cold water pump. Close the hot tap and wait for the water pump to stop pumping. Your system is now pressurised.
6. Turn on your STC-3008 controller. You should see the water temperature (blue) and diesel heater air temperature (red) being displayed. The LED above the water temperature should be illuminated but not the one above the air temperature.
7. Turn on your diesel heater. Check that the diverter fully closes off the airflow to the van/heater when the arm is moved.
8. After 2-3 minutes you should see the red temperature reading on the controller starting to rise. When the temperature reaches 40 degrees the red LED above the controller should illuminate and the pump should turn on. When the water temperature starts to rise you can turn off the diesel heater.
9. (DC only): Switch on the Solaris. Raise the voltage of the leisure battery by proving at least 200 watts either from the engine of the vehicle, a mains charger or solar power. The Solaris should start to count down and switch on the element when it gets to 0 (you can press 'ENTER' to switch between voltage and countdown time). The red light on the front of the tank will come on and you should see the water temperature on the controllers start to rise.
10. (AC/Dual element tank only) Apply AC power and verify that the temperature is increasing with the temperature set on the thermostat.
11. Open the hot tap and enjoy the lovely warm water from your Bobil Hybrid!



## Troubleshooting

The Bobil Air Hybrid should give you many years of service, however if you notice that things aren't quite performing as expected, then check for the following problems:

Behaviour	Solution
Circulation pump not activating	Check voltage across the controller terminals is correct Both red and blue LED lights should illuminate with cool water and diesel heater powered on, if not then check settings. Ensure controller settings are correct Check wiring Debris is stuck in the inlet of the pump
Airlock in system	Circulation pump is above hot water outlet from tank
Controller not powering up	Check wiring/fuses
Solar controller not switching relay	Green light on the PCB indicates relay status. Ensure controller is in P-2 mode. Controller parameters should be as recommended as above.
High current relay not switching	Check wiring; 12v should be applied across the signal terminals
Heater element not turning on	Temperature dial set too low Solaris not set or wired correctly Controllers powered off
Bubbling noise in system	Air is getting into the system through the cold pump

Any other issues? Please do get in touch, we're here to help!

## Tech Specs

Parameter	Value
Capacity	10 litres
Maximum pump pressure	20PSI
Power	200w (DC), 800W (AC), 2200W (Diesel)
Pump and controller power consumption	1 amp in operation. 0.3 amps in standby.
Electric heating time 15 to 60 degrees	DC: 125 minutes, AC: 40 minutes
4kW + diesel heating time 15 to 60 degrees	15 minutes
2kW + diesel heating time 15 to 60 degrees	35 minutes
Tank dimensions	430 L X 270 W x 280 H
Certification	This product is CE marked



We would love to know what you think!

Please let us know by leaving a review through the link sent through when you made your purchase, or email us at [info@bobilvans.co.uk](mailto:info@bobilvans.co.uk)!

You can also share photos of your installation on the 'Bobil Water Heater Users', Facebook page, we'd love to see them!

[www.bobilvans.co.uk](http://www.bobilvans.co.uk)

@bobilvans



©2023 Bobil Vans Ltd

Registered in England. Company no: 13307438.

VAT reg no: 376 3711 79.