

# BOBIL VANS 12V/AC/DUAL ELECTRIC WATER HEATER WITH STC-1008

## INSTALLATION INSTRUCTIONS

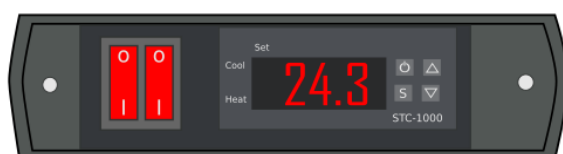



## Important Safety Instructions! Please save these instructions!

This manual contains important safety, installation, and operating instructions for the Bobil Air Electric.

The manufacturer accepts no liability for damage by:

- Incorrect assembly.
- Damage resulting from mechanical influences or excess voltage.
- Modification or tampering with the unit without expressed permission from the manufacturer.
- Used for purposes other than described in this manual.

### General safety

- Firmly secure all cables and hoses.
- In the event of product failure, do not attempt to repair the water heater. Inadequate repairs may cause serious injury.
- Electrical devices are not toys - keep away from children.
- Disconnect the product from the battery and mains power each time before cleaning or maintaining the heater.
- This product is for 12V battery banks and 230V AC circuits only. Make sure your voltage specification is within the input voltage range expressed.
- Install and store the product in a dry and cool place.
- Keep electronics away from liquids!
- Do not use the product if physically damaged or with visibly perished hoses.

### Installation

- Ensure secure location where it cannot tip or fall.
- If necessary, verify installation with a qualified electrician or installer.
- Do not use a water pump with a pressure exceeding 20psi.
- Lay cables so they cannot be damaged or be a tripping hazard.
- Do not operate in salty, wet, or damp environments; in the vicinity of corrosive fumes; in the vicinity of combustible material; in areas with risks of explosions.
- Ensure proper cable sizing for currents generated.
- Over-current protection devices should be on the positive line.

## Thank you for buying our products!

Small businesses like ours only exist because of the support of our customers. We appreciate you purchasing from us, and hope that you have a great experience.

If you have any installation questions or queries then just get in touch, we're here to help.  
Contact us at [info@bobilvans.co.uk](mailto:info@bobilvans.co.uk) or on the phone at +44 1275 261074

## What comes in the box?

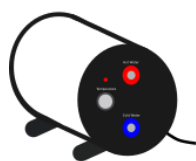

230v, 12v or dual element tank



Solaris Controller  
12V & dual only



Drain valve, hose  
and washers

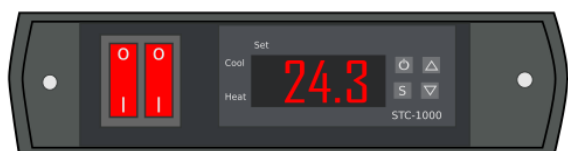

Single Controller (STC-1000)

## Preparing your installation area

The tank should be installed in a cupboard or locker which is clean, dry, ventilated, accessible and free of explosive gases or vapour such as those given off by charging batteries.

Space should be left in front of the heater so the hoses are not kinked and the temperature dial is accessible.

## Installation

Screw the overpressure valve onto the tank- hand tight is sufficient. Screw the tank down securely.

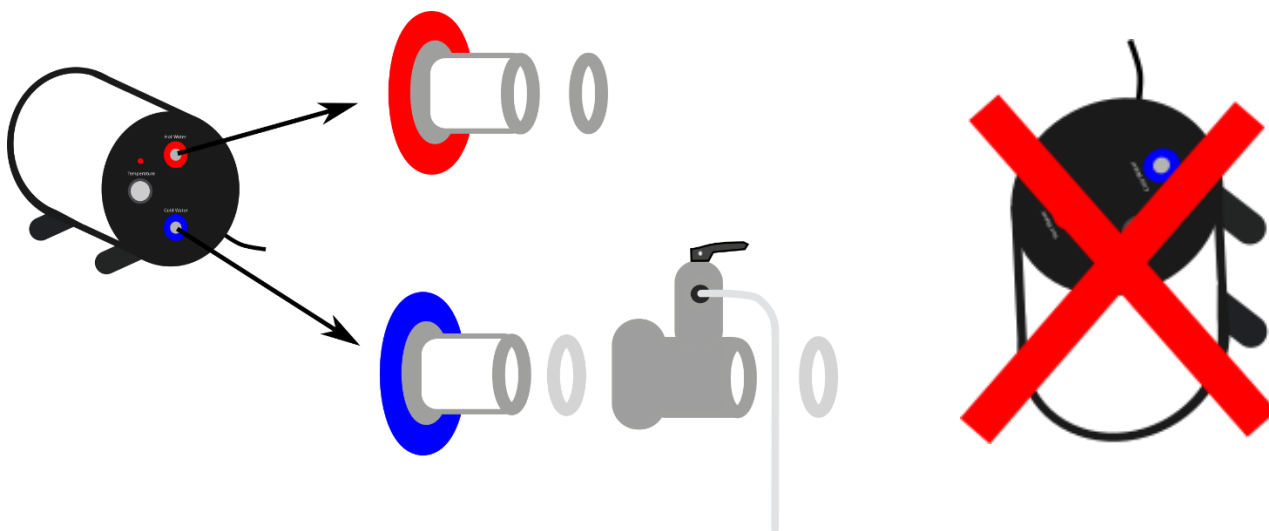

**The tank cannot be mounted vertically.**

The tank is designed for both barbed fittings or 12mm push fit camper van plumbing. The tank thread is a standard  $\frac{1}{2}$ " Male thread, for you to screw your needed plumbing adaptors on to.

- For flexi-hose, you can use a  $\frac{1}{2}$ " to barb brass fitting with washers.
- For 12mm John Guest pushfit, you can use  $\frac{1}{2}$ " Female to 12mm pushfit fittings.
- Both of these we sell on our website.



You can use 15mm push fit plumbing but you may need to modify the fitting so the washer seals against the flat face of the tank. Alternatively you can get 12mm fittings for the tank with a 12mm-15mm reducer.

Direct the clear drain hose from the valve down and outside the van or somewhere where water can drain (like into a sink or grey water tank). We recommend having easy access to the tank front, where the connections and temperature knob controller is, for maintenance purposes.

## Plumbing Layout

We would recommend a layout similar to this. An accumulator can also be added after the diaphragm pump to smooth the water flow.

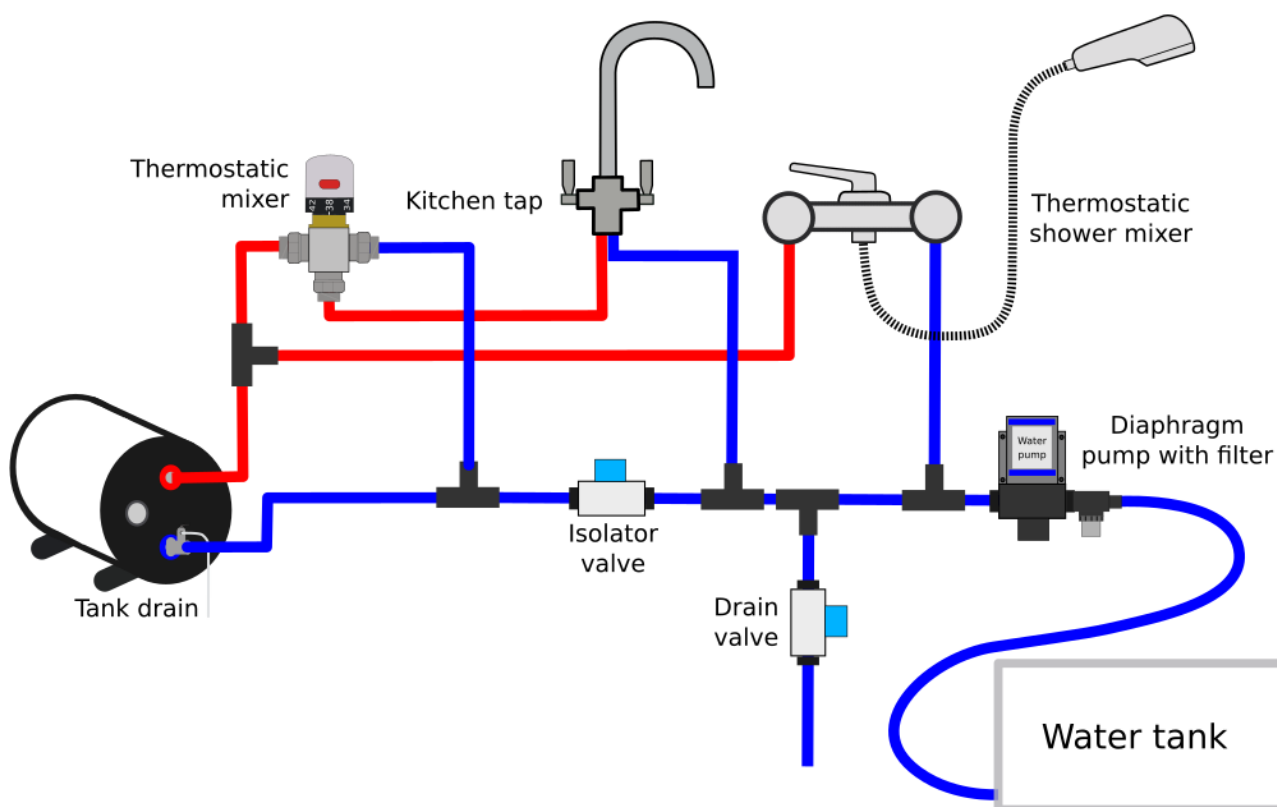

### Thermostatic Mixer (optional)

If you have small children using the taps in the vehicle it may be advisable to fit a thermostatic mixer to the outlet as shown to prevent them touching water which is extremely hot and could scald.

Thermostatic mixer valves are available on our website under “spare parts”.

If you don't fit a thermostatic mixer, we recommend keeping the water temperature on the tank at a lower temperature for safety.



## Setting the Temperature (12V or 230V tanks)

The knob on the front of the tank controls the temperature that the water is heated to. It is linear from 30 degrees until 75 degrees.

You can also use the STC-1000 controller (explained later in these instructions) to set the temperature instead.

## Setting the Temperature (Dual Voltage tanks)

There are 2 elements in the tank, the 800W AC element, and the 200W DC element.

The dual voltage tank is wired so that the dial on the front of the tank controls the temperature in the tank when being heated by the AC element.

The STC-1008 temperature controller controls the temperature when heated with the DC element.

**You must wire the DC element through the controller** else the element will stay on permanently until the internal thermal cut-out permanently disables the heating. Resetting this device involves taking the tank apart so **please ensure the wiring is correct.**

## Tank Temperature Sensor

The tank has a temperature sensor built into it which can be plugged into our temperature display panels. You will find the cable for this cable tied into a loop next to the cold inlet.

If this cable is not long enough, you can extend this cable to your desired length.

## Electrical wiring: AC element

We would suggest wiring the element to a fused spur so you can switch the heater on and off when not needed. The AC fused spur should be double pole to comply with campervan regulations. You can then wire this fused spur to your inverter or a circuit from your EHU. Consult an electrician if unsure.

The element will be controlled by the temperature knob on the front of the tank for both the AC tank and the dual element tank.

The AC element is 800W AC.

**Do not plug the 230V element into a 110/120V supply, or to a 12V supply.**



## Electrical Wiring (12V DC kit)

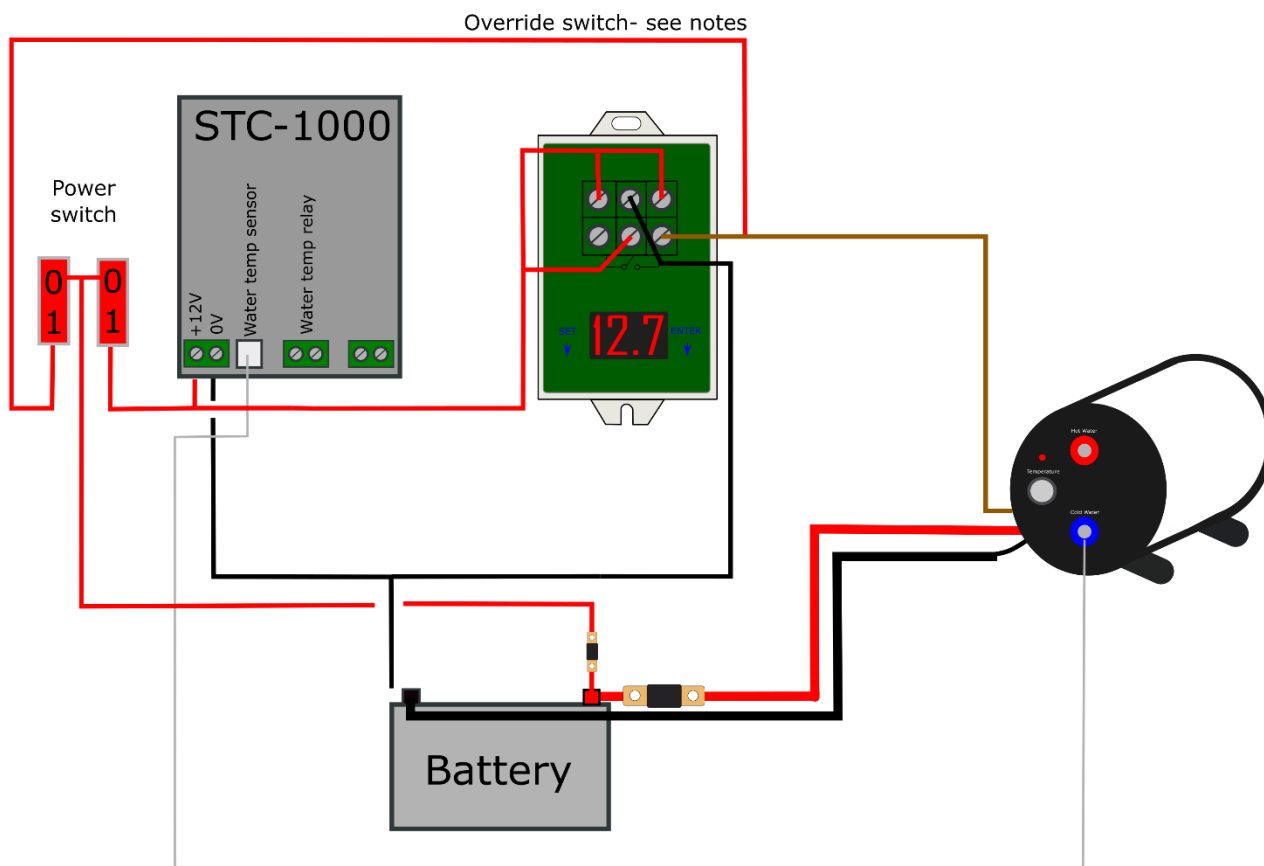

## Electrical Wiring (Dual Voltage Tank) – AC Wiring not shown for clarity.

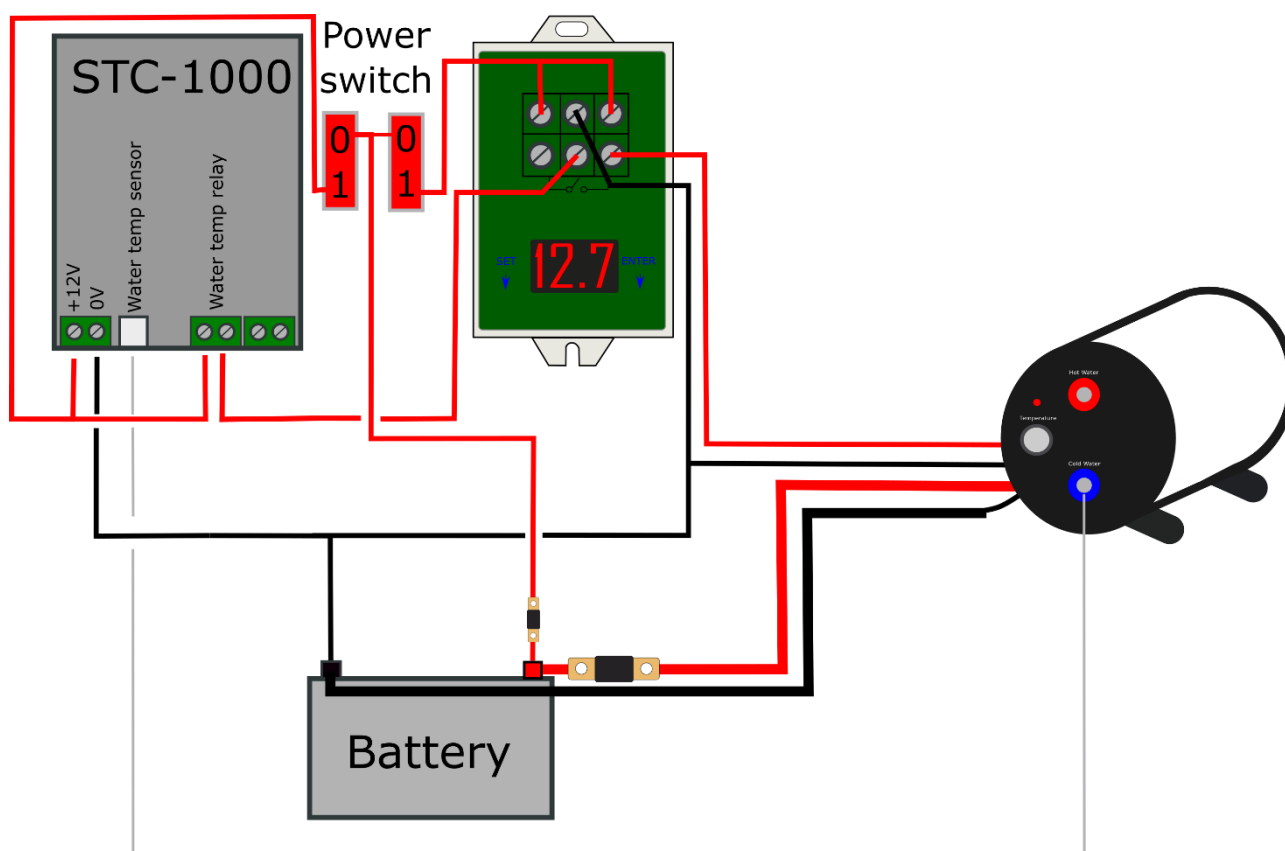

Wire up the controllers as shown above for your tank type. Note that to get an accurate reading the voltage sensitive controller should be wired so that the voltage drop across the cable is no more than 1%.

Also note that the 200W element will draw 17 amps from the battery so ensure that the cable you choose for this is adequately sized and fused. Heating from cold to 70 degrees will take around 145 minutes.

For the 12V tank, there will be a brown wire, and no relay. The relay for the 12V tank is inside the tank, so the brown wire needs to connect to the Solaris as shown, with the red/black wires going to power/ground respectively.



## Voltage Drop Issue

The Solaris is sensing the battery voltage via the wires powering the unit. If you see a discrepancy in the sensed voltage when the heater is on, this could be because you are measuring a voltage drop somewhere in the system caused by the heater load.

This is common if you are using the same fuse box for both Solaris and heater power. If this happens, run a second (fused) sense cable directly from the battery terminal to the sense pin on the Solaris as shown here.

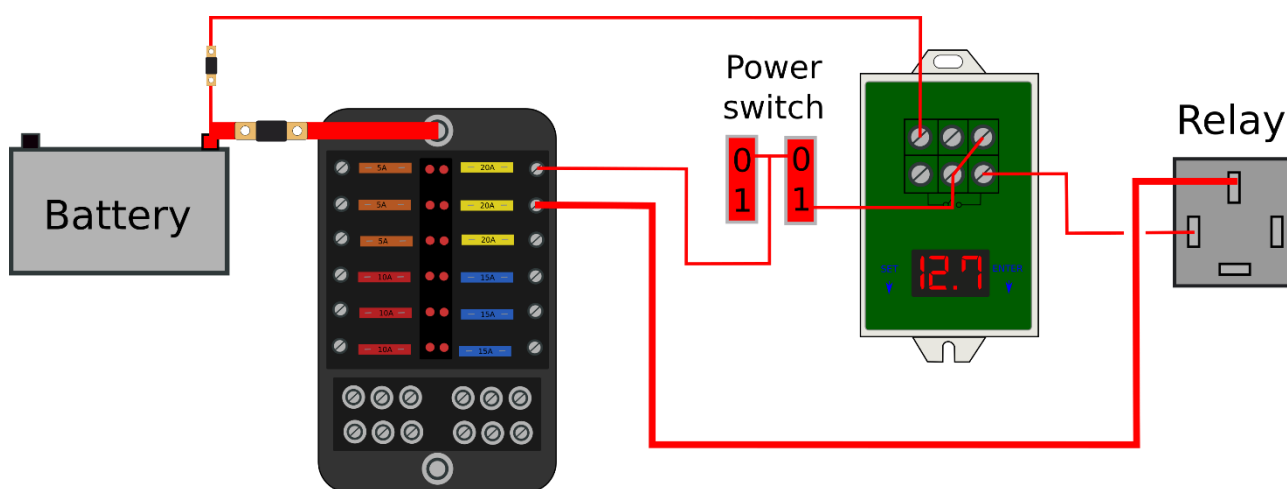

## Override switch

It is possible to connect the tank straight to the battery but this gives no protection against the battery being flattened which could cause permanent damage to the battery.

If you want to do this you can fit the wire as shown in the above diagram(s) on pages 7 and 8, which will override the solaris, so you can manually turn the heating element on/off. However this is only recommended where you have low battery protection elsewhere in your electrical system, such as a BMS in a lithium battery, or a low voltage disconnect relay to avoid flattening your battery.



## Programming your Single Controller

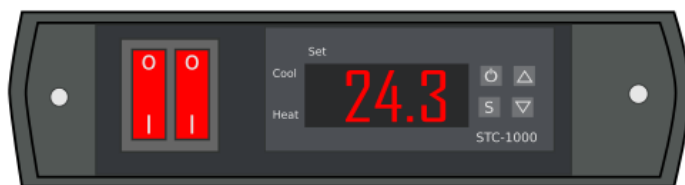

F1: Set to 75 degrees

F2: Set to 3 degrees

1. To program this sensor, hold down the 'S' key until 'F1' is displayed.
2. Press 'S' again to enter programming mode.
3. '10' will be displayed - to alter this number hold the 'S' key and press the up arrow until 75 is reached. Note: you have to keep pressing the button, holding it down won't change the value.
4. Repeat this with 'F2', and change '0.5' to '3.0'. This means the temperature has to drop by 3 degrees before heating is reactivated.

## Wire gauge

Use this table for suggested wiring sizes for the controller and the 12v element.

Distance	1-2M	3M	4-6M	7-8M
Element (mm <sup>2</sup> )	2.5mm	6mm	10mm	16mm
Element (AWG)	14 AWG	10 AWG	8 AWG	6 AWG
Controllers (mm <sup>2</sup> )	1mm	1.5mm	2.5mm	2.5mm
Controllers (AWG)	17 AWG	16 AWG	14 AWG	14 AWG

Use a 2A fuse for the controller and a 25A fuse for the element. The AC element (if your tank has one) should be fused at 5A AC.



## Voltage Controller Programming (Solaris – 12V/Dual Voltage)

For a video on how to program the controller, scan the QR code.



The controller will wait for the battery voltage to go above the programmed limit (V-1). When it does, it will wait for a short time delay (T-1) before switching on the relay. The relay will stay closed until the voltage drops lower than the second programmed limit (V-2), when it will start a second time delay (T-2) before switching the relay off.

We recommend that T-1 is set to a minimum of 300 seconds which will stop the relay being switched too quickly if there is not enough power to maintain the voltage. Likewise, the second time delay should always be set to '0' so the relay clicks off quickly to free up power if there are any other loads placed on the battery

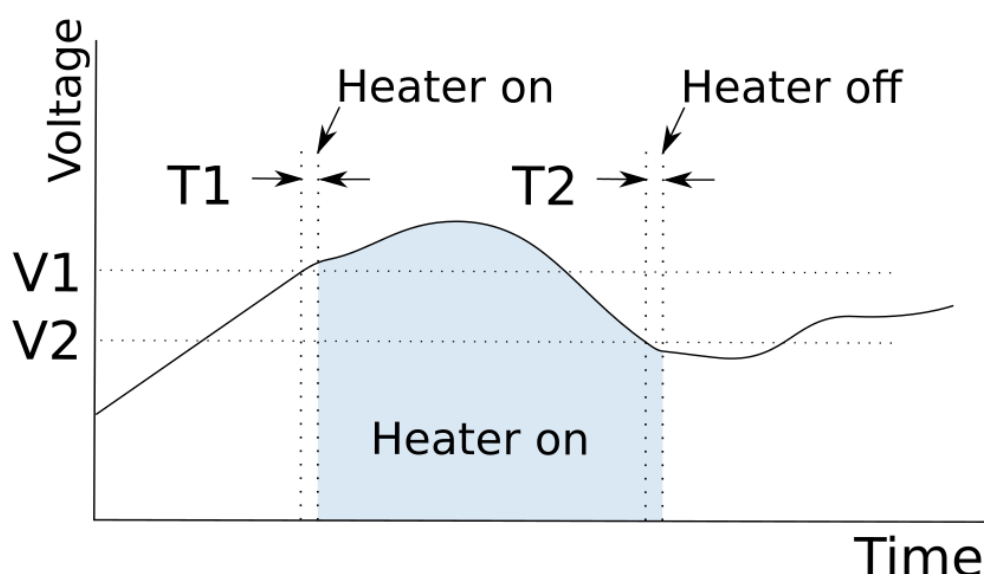

Note that for the element to stay on, you must have enough power coming in to maintain the voltage. If the element is turned on then immediately goes off, it is because the power supplies are not sufficient.

### Suggested Solaris Values

The following voltages are only suggestions, you may need to alter them according to your battery and solar set up.

Suggested values	Turn on threshold (T1)	Turn off threshold (T2)
Lead acid/AGM batteries	14.0	12.8
Lithium batteries (Summer)	13.5	12.4
Lithium batteries (Autumn-Spring)	13.8	12.7



We would love to know what you think!

Please let us know by leaving a review through the link sent through when you made your purchase, or email us at [info@bobilvans.co.uk](mailto:info@bobilvans.co.uk)!

You can also share photos of your installation on the 'Bobil Water Heater Users', Facebook page, we'd love to see them!

[www.bobilvans.co.uk](http://www.bobilvans.co.uk)

@bobilvans



©2024 Bobil Vans Ltd

Registered in England. Company no: 13307438.

VAT reg no: 376 3711 79.