

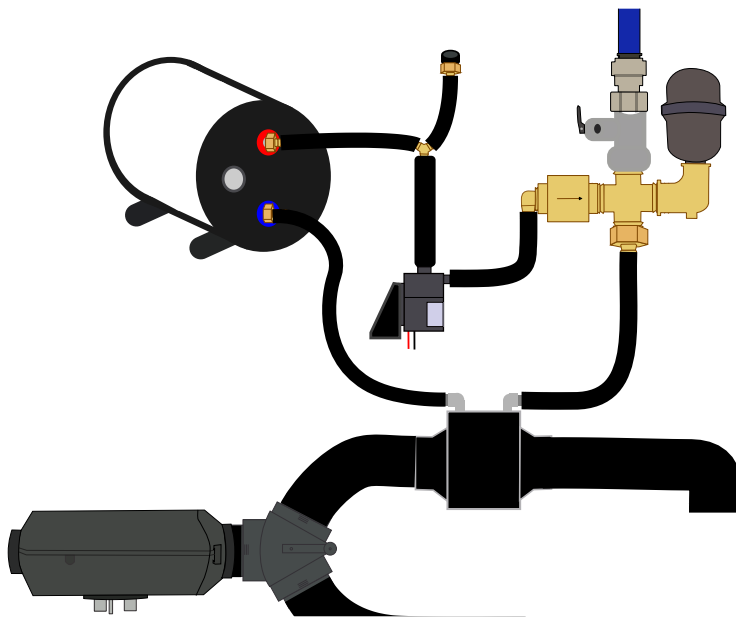

BOBIL VANS AIR HYBRID DUAL VOLTAGE WATER HEATER

INSTALLATION INSTRUCTIONS





Important Safety Instructions! Please save these instructions!

This manual contains important safety, installation, and operating instructions for the Bobil Air Hybrid.

Bobil Vans accepts no liability for damage by:

- Incorrect assembly.
- Damage resulting from mechanical influences or excess voltage.
- Modification or tampering with the unit/system without expressed permission from the manufacturer.
- Used for purposes other than described in this manual.

General safety

- Firmly secure all cables and hoses.
- In the event of product failure, do not attempt to repair the water heater. Inadequate repairs may cause serious injury.
- Electrical devices are not toys - keep away from children.
- Disconnect the product from the battery and mains power each time before draining, cleaning or maintaining the heater.
- This product is for 12V battery banks and 230V AC circuits only. Make sure your voltage specification is within the input voltage range expressed.
- Do not use the product if physically damaged or with visibly perished hoses.

Installation

- Ensure secure location where it cannot tip or fall.
- If necessary, verify installation with a qualified electrician or installer.
- Lay cables so they cannot be damaged or be a tripping hazard.
- Do not operate in salty, wet, or damp environments; in the vicinity of corrosive fumes; in the vicinity of combustible material; in areas with risks of explosions.
- Ensure proper cable sizing for currents generated, with appropriate fuses.

Due to the nature of ways the Bobil Hybrid systems can be fitted, we cannot account for all install variations and eventualities in this instruction manual. If you install your system in a way which deviates from these instructions without contacting us beforehand, then we cannot accept fault for any issues that might occur due to incorrect assembly or use, and as such, broken parts would not be covered under warranty.

If you have [any questions](#) about your installation,

Please email us at info@bobilvans.co.uk

What comes in the box?

Please unpack all bags/boxes to ensure you have everything before starting installation.

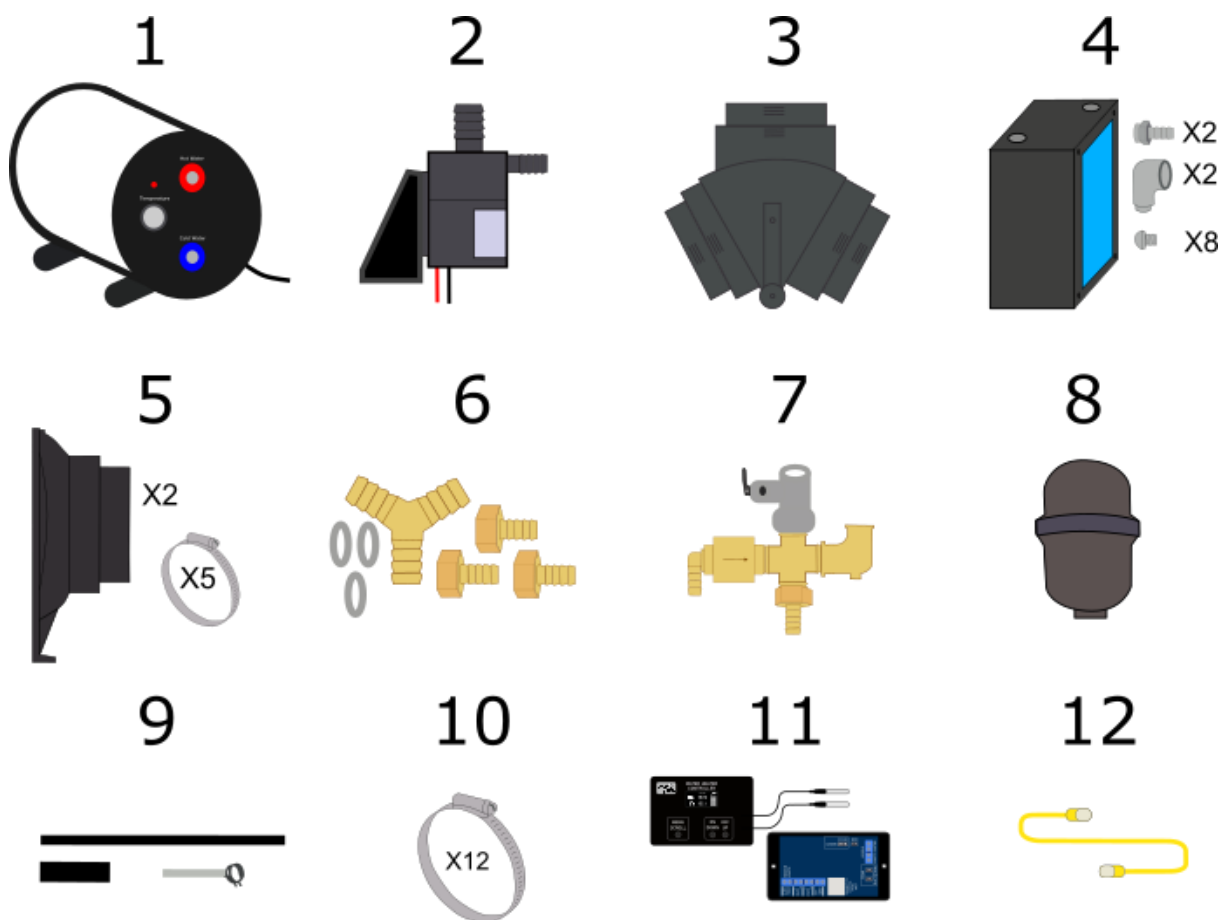

1. 10L Hybrid Tank	7. Central Plumbing Unit
2. Circulation Pump with bracket	8. Expansion Tank
3. Diverter + Tri-Colour Servo Cable	9. Hose (3 types; large + small black, clear)
4. Heat Exchanger & fittings	10. Jubilee Clips (x12)
5. Ducting Adaptors (x2) & Clips (x5)	11. Smart Controller
6. Brass Fittings Bag	12. Controller Cable & Accessories*

* This includes a diverter servo extension cable and a temperature sensor cable.

If ordered, you will also receive two level sensors.

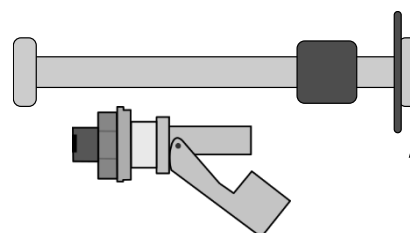



Preparing your installation area

The tank should be installed in a cupboard or locker which is clean, dry, ventilated, accessible and free of explosive gases or vapour such as those given off by charging batteries.

The heat exchanger can be installed remotely from the tank, even under the vehicle. If mounted under the vehicle, the unit should be protected from road debris and hoses should be secured where they won't be damaged by being passed through the floor of the van.

Space should be left in front of the heater, so the hoses are not kinked, and the temperature dial is accessible.

Scan these codes with your phone camera to watch some installation videos.



Installing in a Van



Intro to the Kit



Smart Controller Features

To install the Bobil Air Hybrid Kit you will need the following tools:

- Adjustable Spanner/Spanner Set
- Hose cutters (or a sharp knife)
- Small flat head & Phillips screwdriver
- Socket set
- Drill & 4mm drill bit

Thank you for buying our products!

Small businesses like ours only exist because of the support of our customers. We appreciate you purchasing from us, and hope that you have a great experience.

If you have any installation questions or queries then just get in touch, we're here to help. Contact us at info@bobilvans.co.uk or on the phone at +44 1275 261074 (Mon-Thu 9-1)

Installation

1. **TANK CONNECTIONS:** Screw the barbed fittings onto the tank, using the supplied washers to seal. Hand tighten the brass fittings, then apply a 1/6th turn with a spanner. **Do not overtighten.**

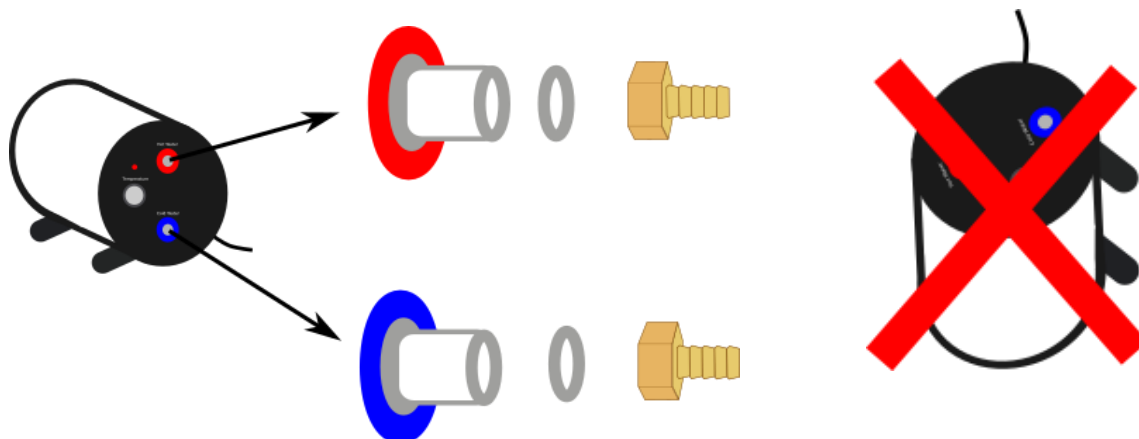

The tank must be mounted horizontally as shown.

2. **HEAT EXCHANGER ASSEMBLY:** Drill a 4mm hole into one of the adaptors. Pass the temperature sensor through the hole, then assemble the ducting adaptors onto the sides with the temperature sensor inside so it sits in the airstream. (Note that this is a change in technique compared to some of our Youtube videos!)



- Depending on your layout, you may find it more convenient either use the elbow fittings, or the straight fittings.
- You can add the sensor to either side of the exchanger but it should face towards the heater during final assembly.
- The exchanger can be mounted in any orientation, so that the inlets are either on top, on the side, or underneath.

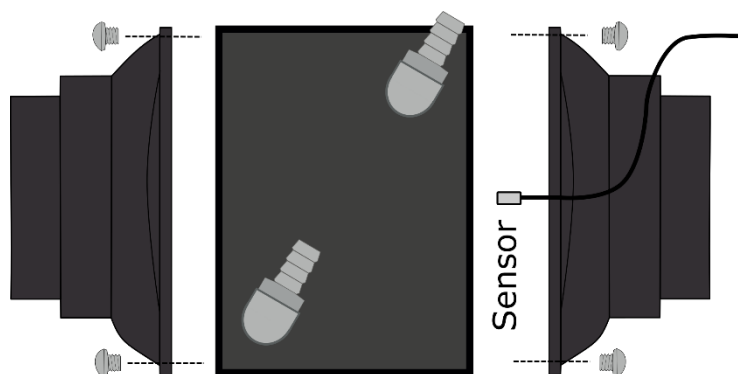

3. **PUMP ASSEMBLY:** Assemble the pump assembly using hose clamps as shown. The larger Y piece goes onto the larger 13mm ID hose. Don't tighten hose clamps yet.

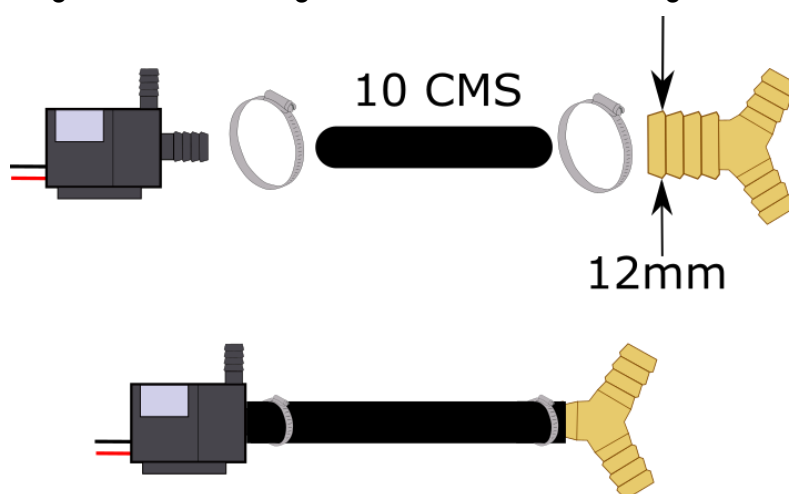

- **ATTACHING THE PUMP:** Cut a length of the smaller hose and attach it to the hot water outlet on the tank with a jubilee clip. Put the other end into the Y piece on the pump assembly you have just assembled. Cut another piece at a similar length and attach to the 3rd end of the Y piece.
- Add your remaining barbed fitting to the open end of hose – this is your hot water line. The open end is a ½" F thread, for you to attach your required plumbing fittings to.

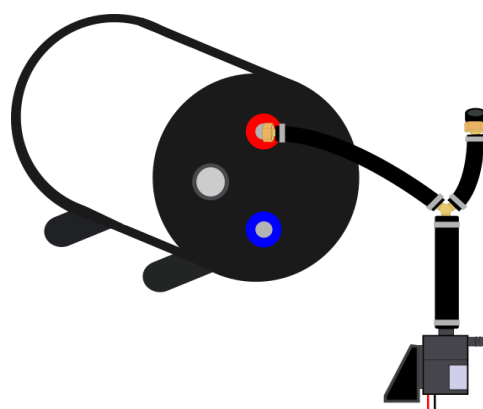

- Rotate the pump to point towards where your central plumbing unit will be and tighten all the hose clamps.
- For John Guest 12mm push fit plumbing, you'd need a ½" Male to 12mm JG push fit fitting to connect this brass fitting to 12mm push fit pipe. We do sell this on our website.



DIVERTER ASSEMBLY: Assemble the diverter by clipping together the two halves of the units with the flap in between. Ensure the servo for the diverter flap motor is on the top. The 3 coloured wire connects the servo to the slave board – if required, you can use the included servo extension to lengthen this connection. (see wiring diagram on page 12)

5. **CENTRAL PLUMBING UNIT:** The central plumbing unit will come pre-assembled in the box.

- Plumb the central plumbing unit from your cold feed onto the ½" thread onto the overpressure/drain valve.
- Mount the central plumbing unit by screwing through the brass bracket.
- Drill a 10mm hole through the floor of the van for the drainpipe.
- Attach the clear hose to the overpressure valve with the included clip.

Below is an example of how to plumb it into your cold water feed using 12mm JG push fit. We recommend fitting an isolator valve on the cold water inlet for maintenance (not included)

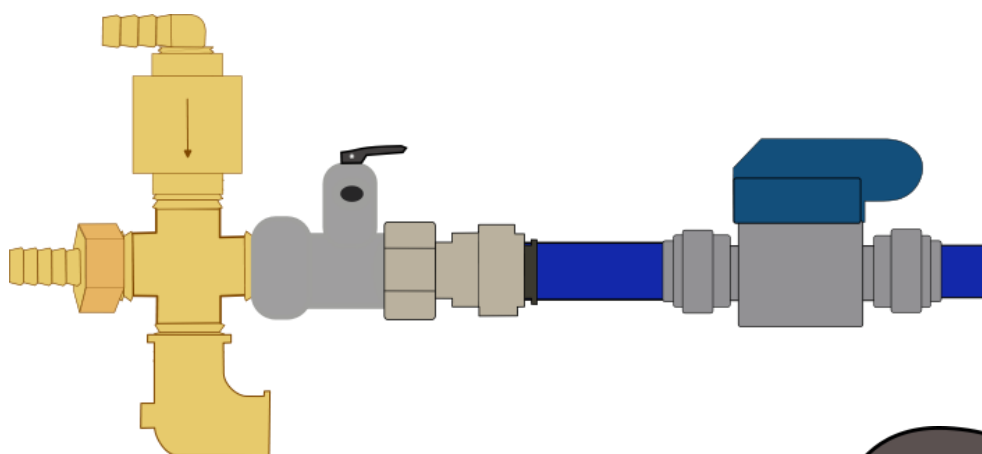

The expansion vessel is pre-set to 35PSI, suitable for pump pressures up to 30SPI so there is no need to alter the pressure. However, the pressure should be checked periodically and set at 5PSI above your pump pressure. You can use any bike pump with gauge to set the air pressure.

Screw the expansion vessel into the threaded elbow as shown.

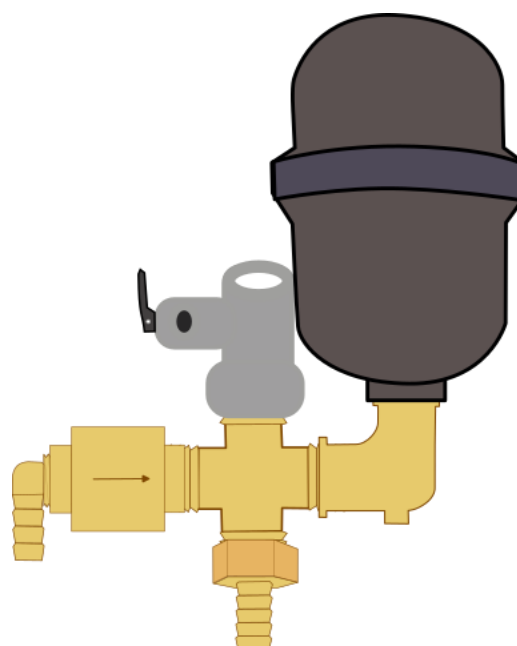

Final Assembly

- Assemble the heater kit as shown with the remaining hose.
- Ensure that hose clamps are used on every joint.
- If you need more hose, we sell it by the meter on our website.
- The hose connecting the Central Plumbing Unit should enter the exchanger at the opposite side to the where the air enters the exchanger.
- The ducting should be secured with the supplied jubilee clips, and the ducting exhaust from the heat exchangers can be used to either heat a shower room, garage or vented straight outside through the floor of the van.
- Ensure the duct sensor is closest to the diverter.
- The pump should be lower than the water level as it is not self-priming and so that any air from the tank is allowed to escape.

The diverter **MUST** be fitted between the heater and the heat exchanger!



Plumbing Layout

Here is a suggested layout for your van plumbing. We especially recommend the addition of a thermostatic mixing valve if you have small children as the water coming out of the tank can be 75 degrees if electrically heated (We do sell a thermostatic mixer kit specifically for the Hybrid).

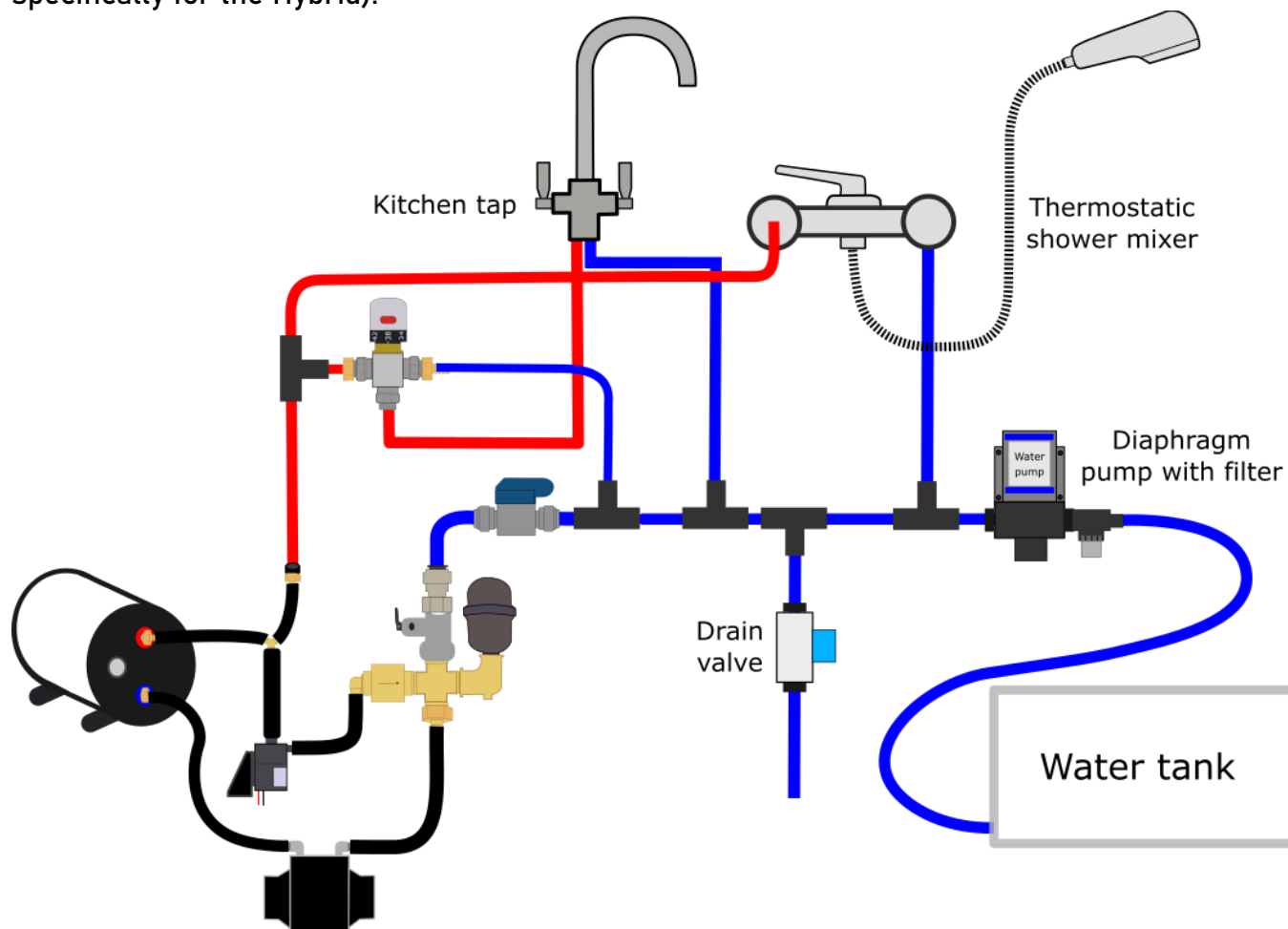

- We do recommend using 12mm JG push fit plumbing with our Bobil Hybrid kit as it works well and is a popular campervan plumbing choice. We do sell all 12mm JG fittings and pipe on our website.
- If using 12mm flexible plumbing, we would suggest using pipe inserts on the hot pipe to prevent them softening in use.
- If you plan to leave your Bobil hybrid system in below freezing conditions, you **must drain the tank to prevent freezing damage**. To do this, unscrew the screw in the overpressure valve, and lift the lever up to drain the tank.

Water level sensor wiring (optional)

If you ordered level sensors, please follow this page to install them.

Before you start, add crimped spade connectors to the wires for easy connections when the time comes.

To fit the fresh level sensor:

- Drill a 35mm-38mm hole in the top of the tank.
- Drop the sensor in and centre it in the hole.
- Drill a 3.5mm hole underneath one of the holes in the sensor.
- Drive one screw into the hole to form a thread.
- With the sensor in position, drill the other four pilot holes.
- Remove the first screw. Remove any swarf from the sensor and the underside of the hole.
- Replace the sensor and gasket, refitting the first screw.
- Drive the other four screws into the holes to secure the sensor.

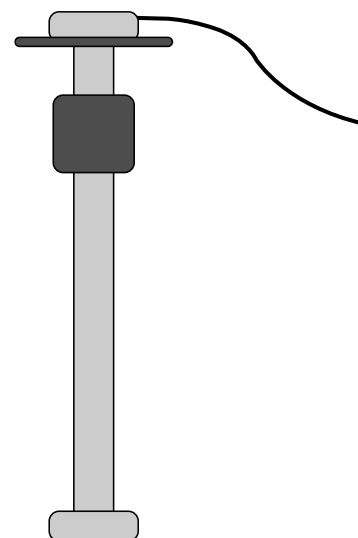

An optional spacer is supplied in case the wall of your tank doesn't allow the sensor to sit correctly.

To fit the waste sensor:

- Drill a 22mm hole in the side of the tank at a level which corresponds to a level of around 80% of the tank volume.
- Once the sensor fits through the hole, tighten the collar on the outside to lock the sensor in place. You should ensure that the sensor is fitted in the orientation shown here.

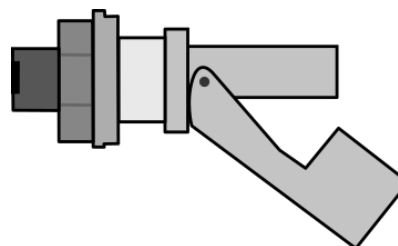

There is no polarity on the level sensors.

Controller Wiring

The Bobil Smart Controller is made up of two boxes, one which can be mounted in the living area (master controller), and one which is situated near the heater itself (slave unit). All connections are made from the slave unit except for the air temperature sensors which come from the master controller.

The yellow cable connects the 2 boxes together – this cable is 5m long, we don't recommend extending it as this can cause issues.

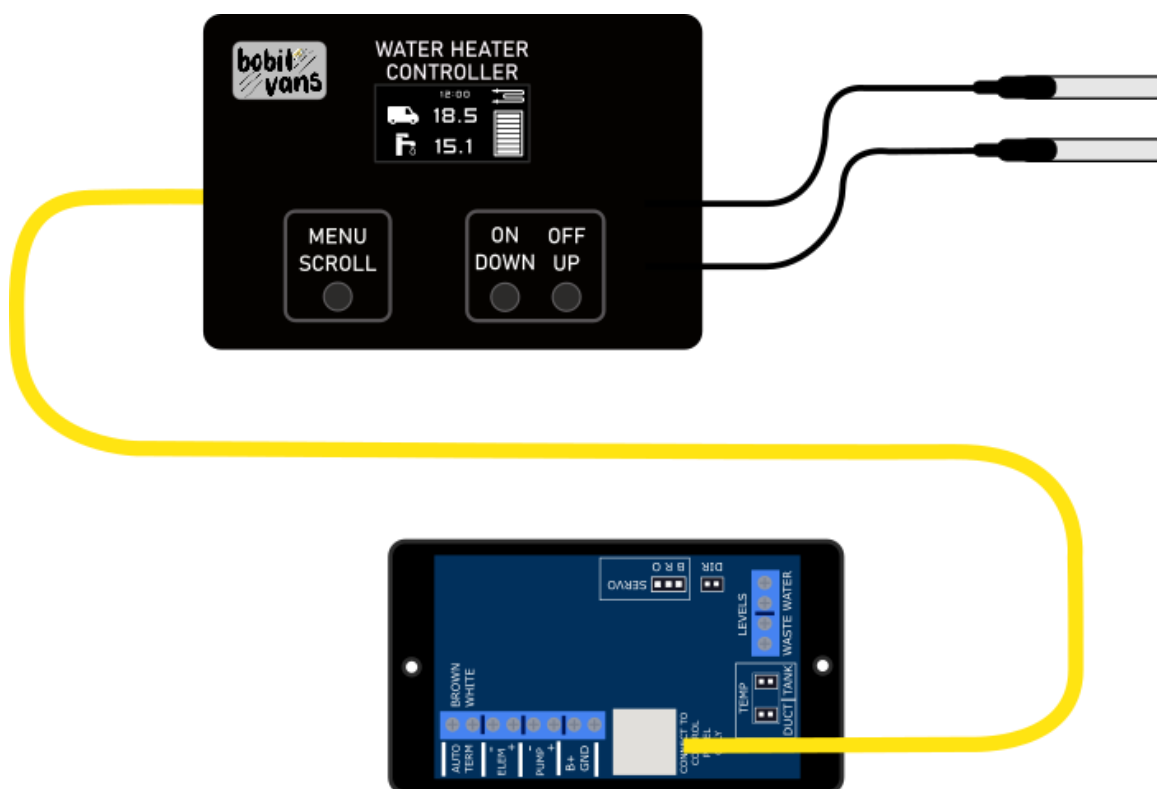

The two sensors from the master controller are for measuring the internal and external temperatures. The internal sensor should be mounted high up in the main living space, away from any direct flow from the heater outlet duct.

The external sensor can be mounted anywhere outside the vehicle but must be protected from moisture. We would suggest attaching it to the underside of the van, or alternatively you can drill a 6mm hole through the floor and push it through there.

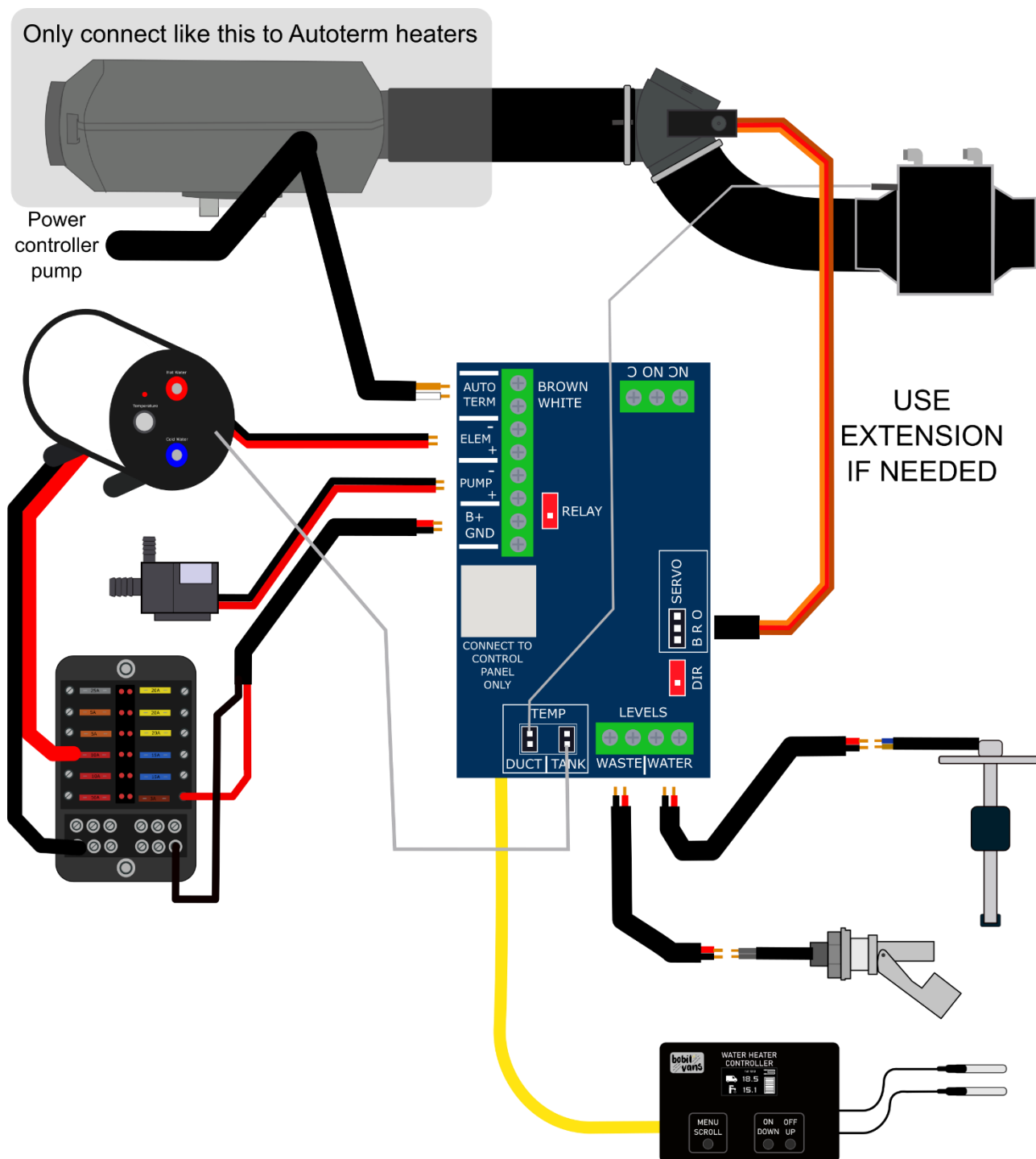

Do not wire the slave board directly to a Chinese heater - it communicates using radio signals. Follow the instructions in the Smart Controller User Guide to pair your heater with the Smart Controller.

When the connections have been made to the slave board, either drill holes or remove some of the tabs on the lid of the box to allow the wires to come back through.

Only wire the Autoterm heaters directly to the slave board. Use the brown/white wires that are separate from any other wiring loom, covered with heat shrink on the end.



If your heater has a 'remote start' function which requires a 12v signal, you will need to wire the heater using the relay. Connect the activation voltage to the common pin 'C', and the heater to the normally open pin 'NO'. Please check the wiring diagram of your heater before wiring anything up.

Eberspacher heaters have a yellow wire (called 'S+' or easystart in the documentation, normally pin 4 on the first connector out of the heater), marked 'ge' in the manual.

Some heaters can be made to run on full by interrupting one of the signal lines. If so, you can wire these through the 'C' and 'NC' pins. You will need to activate the relay using the switch on the board for these heaters (Autoterm, Eberspacher etc).

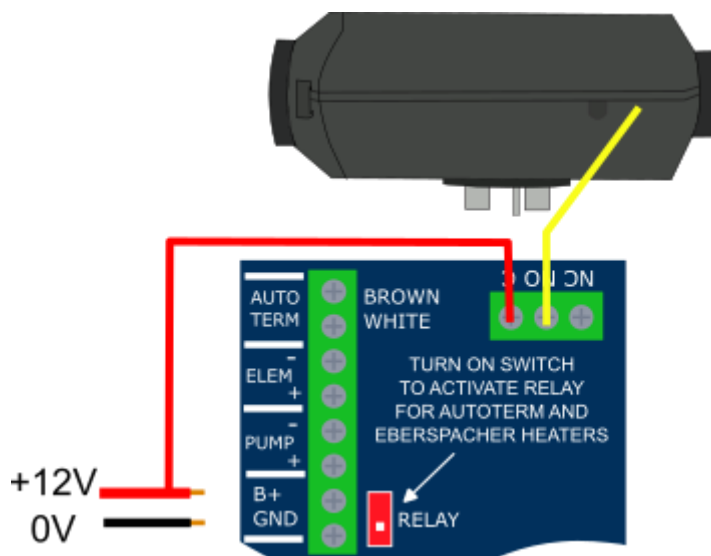

AC Wiring

If you have a 230V wire on your tank (white 3 core wire) then you can wire this to a fused plug, or an AC breaker. We recommend a 5A AC fuse, as the element pulls 800W. The wiring is not shown on the main diagram for simplicity.

The knob on the tank controls the temperature of the water when being heated via AC. MIN is 30C, and MAX is 75C.

Wire Gauge

Use this table for suggested wiring sizes for the controller and the 12v element.

Distance	1-2M	3M	4-6M	7-8M
Element (mm ²)	2.5mm	6mm	10mm	16mm
Element (AWG)	14 AWG	10 AWG	8 AWG	6 AWG
Controllers (mm ²)	1mm	1.5mm	2.5mm	2.5mm
Controllers (AWG)	17 AWG	16 AWG	14 AWG	14 AWG

Use a 2A fuse for the controller and a 25A fuse for the element. The AC element (if your tank has one) should be fused at 5A.

For the connections to the level sensors and the Autoterm, use the thinnest wire you have. We suggest 0.75mm regardless of the distance. The servo is supplied with an extension, if you need longer then extensions are available from our online shop.

Reversing the Diverter

Normally the servo will point to the left for water heating and to the right for air heating. However, you can reverse this by switching the 'DIR' switch.

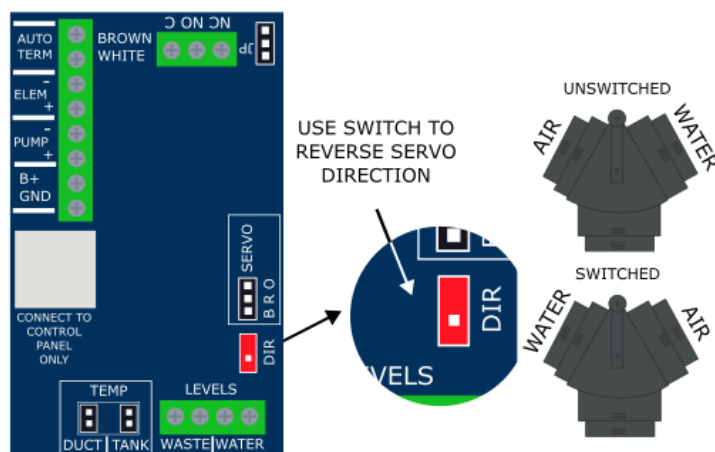

Commissioning the system

To commission your system for the first time, follow these steps.

1. Ensure your cold tank has at least 12 litres in it.
2. Open sink hot tap fully.
3. Turn on the cold water pump and open the isolator valve to the hybrid (if you have one). You should hear water being pumped around the system and filling the tank.
4. You should see water coming out of the hot tap in 1-2 minutes. Close the hot tap and wait for the water pump to stop pumping. Your system is now pressurised.
5. Turn on the controller. Verify that all of the sensors are working correctly, and that the diverter has directed the airflow into the van. If not, then switch the direction on the slave board.
6. Turn on the water heating routine. Check that the diverter fully closes off the airflow to the van.
7. After 2-3 minutes you should see the water temperature reading on the controller starting to rise. Stop the routine and ensure that the diesel heater switches off.
8. (DC only): Switch on the element option on the controller screen. Raise the voltage of the leisure battery to at least 13.5v and ensure at least 200 watts will be available either from the engine of the vehicle, a mains charger or solar power. The controller should start to count down and switch on the element when it gets to 0. The red light on the front of the tank will come on and you should see the water temperature on the controllers start to rise.
9. (AC/Dual element tank only) Apply AC power and verify that the temperature is increasing with the temperature set on the thermostat.
10. Open the hot tap and enjoy the lovely warm water from your Bobil Hybrid!



Common Questions + Answers

My temperature sensors from the tank/heat exchanger don't reach the slave board.
You can cut and extend these cables using thin wire (0.75mm) as needed.

What is the power usage of the elements?

The 12V element draws 200W. The 230V element draws 800W.

How much power does the 12V/230V use to heat up the water?

Around 45Ah to heat the water from 15-60C. The AC element takes a little more power if you run this via an inverter from your batteries due to inverter inefficiencies.

When the water is heated electrically, what happens when the water is up to temperature?

The element will turn off, and providing the element still has a supply of power, it will turn back on when the water drops 3C below the set point to maintain the temperature.

My electric element isn't turning on and my wiring is all correct.

If all electrical connections are correct and working, and the light on the tank is not coming on, there might be a chance that the internal element safety has tripped. If this is the case, please refer to our "element reset" guide on our website.

How quickly does the water cool down when not being heated?

This varies depending on ambient air temperature but around 0.5C/hour in a heated van.

There's a screw on my overpressure valve, do I need to undo this?

The screw is there to keep the drain valve lever held down. If you wish to drain the tank, for cold conditions where water might freeze, undo this screw and pull up on the level to drain the tank. Otherwise, you can leave this screw tighten for normal use (not all valves have screws).

When I select hot water or hot air, my Autoterm/Eberspacher heater isn't turning on.

Ensure you have the relay switch on the board turned on (page 13).

Something on my controller isn't working properly/I can't connect my heater to it.

Please refer to the controller instructions as that has a lot more information.



Troubleshooting

The Bobil Air Hybrid should give you many years of service, however if you notice that things aren't quite performing as expected, please do get in touch, we're here to help!

Email us with your questions at info@bobilvans.co.uk

We would love to know what you think!

Please let us know by leaving a review through the link sent through when you made your purchase, or email us at

[info@bobilvans.co.uk!](mailto:info@bobilvans.co.uk)

You can also share photos of your installation on the 'Bobil Water Heater Users', Facebook page, we'd love to see them!

www.bobilvans.co.uk

@bobilvans



©2024 Bobil Vans Ltd

Registered in England. Company no: 13307438.

VAT reg no: 376 3711 79.