

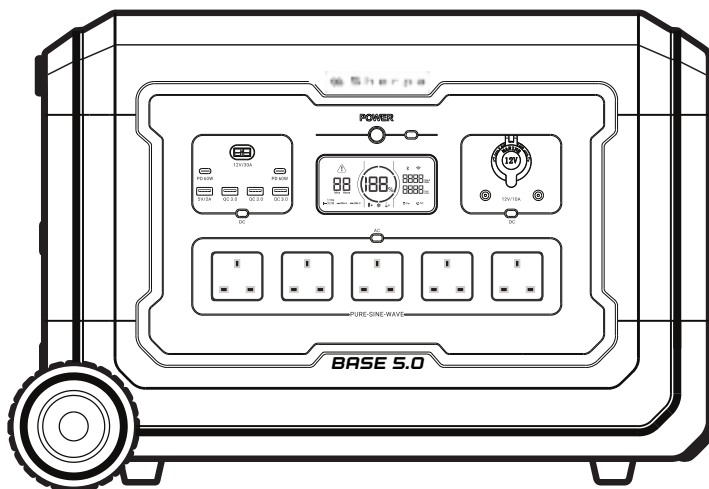

BASE 5.0



Please read the user manual thoroughly before using

CONTENTS

- Box Contents**1
- Product Specifications**2-3
 - Output and Input Specifications2
 - Function Overview4
 - Display Overview5
- Operation Instructions**5-12
- Recharge Methods** 6-12
 - AC Charging6-7
 - Solar Charge Configuration8
 - Charging from a Vehicle9
 - Cascading and Expandable Battery Charging.....10
- Other Functions** 11
 - UPS (Uninterruptible Power Supply)11
 - AC Input Overload Protection12
- FAQ**13-14
- Fault Code and Trouble Shooting**15-16
- Storage & Maintenance**17
- Warranty Exclusions**18
- Disclaimer** 19
- Disposal**20
 - Support20

BOX CONTENTS

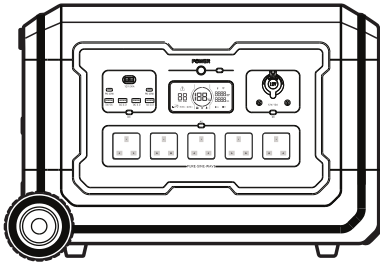

BASE 5.0

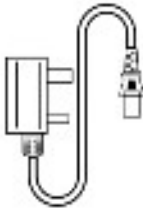

AC Charging Cable

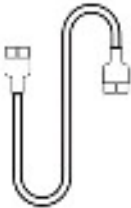

Anderson Cable

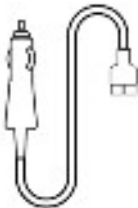

**Anderson to Car
Charging Cable**

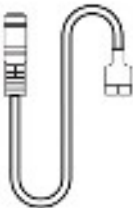

Anderson-7909 Cable

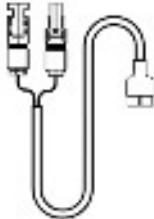

Anderson-MC4 Cable



User Manual

PRODUCT SPECIFICATIONS

OUTPUTS

AC Output	Rated Voltage	220~240Vac
	Rated Power	5000W
	Peak Power	7000W
	Frequency	50Hz
DC12V & Car Auxiliary Output	Rated Voltage	12V
	Rated Power	120W
USB-A Output	5V/3A; 9V/2A; 12V/1.5A (18WMax)	
USB-C Output	5V/3A; 9V/3A; 12V/3A; 15V/3A; 20V/5A (60W Max)	
Anderson Output	12V, 30A (350W max)	

INPUTS

AC Charge Input	220~240V AC 13A Max 2500W Max
PV Input (Anderson)	(12~150V DC) MPPT:18V-140V 15A Max 2100W Max

BATTERY

Rated Capacity	5040Wh
Rated Voltage	48V DC
Battery Type	LiFePO4

GENERAL

IP Grade	IP21
Working Temperature	0~40°C
Dimensions	642 x 305 x 438 mm
Net Weight	51kg

FUNCTION OVERVIEW

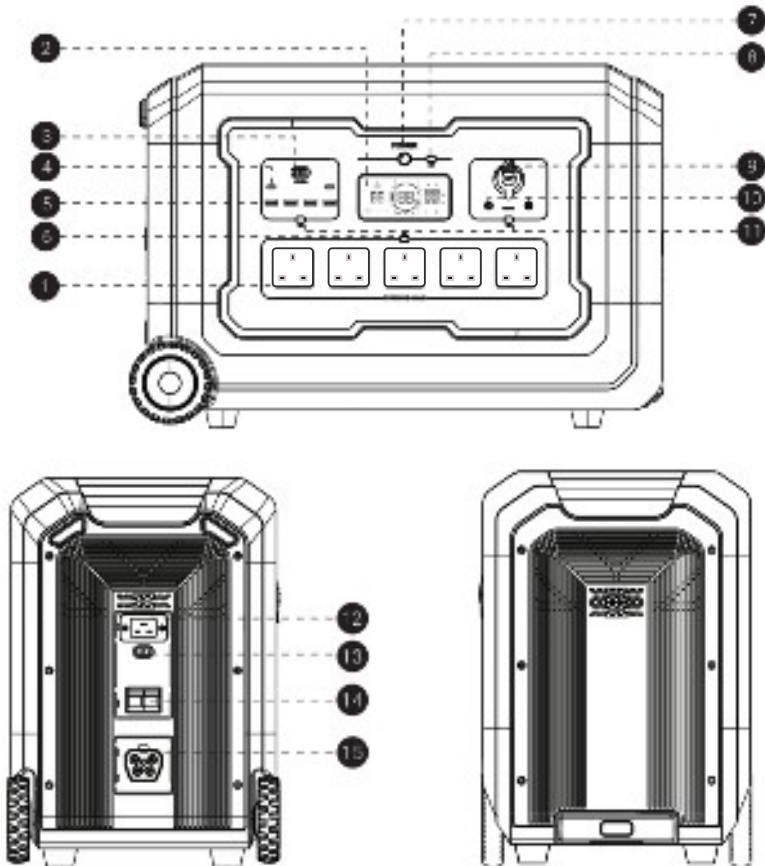

- | | | |
|-----------------------------------|----------------------------------|--------------------------------|
| 1. AC Output Port (13A Max total) | 7. Main Power On/Off | 13. Anderson Input Port |
| 2. LCD Screen | 8. IOT On/Off | 14. Circuit Breaker Protection |
| 3. Anderson Output Port | 9. 12V Car Auxiliary Output Port | 15. Extra Battery Cascade Port |
| 4. USB-C Output Port | 10. DC 5521 Output Port | |
| 5. USB-A Output Port | 11. DC Output Power On/Off | |
| 6. AC Output Power On/Off | 12. AC Charge Input Port | |

DISPLAY OVERVIEW

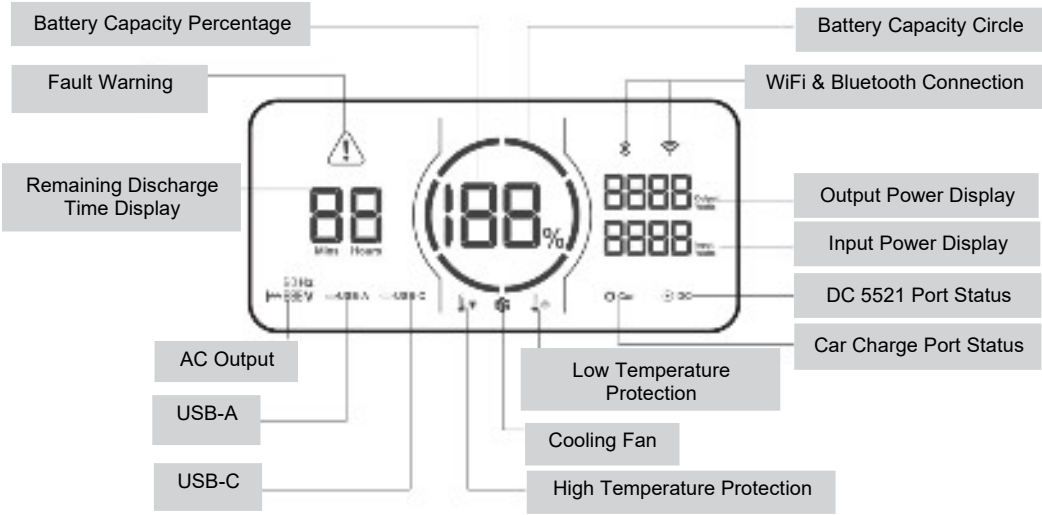

OPERATION INSTRUCTIONS

Powering the power unit ON/OFF:

Long press the main power button once to turn the BASE 5.0 ON. No outputs will be activated, just the display. Press and hold the main power button for at least 3 seconds to turn the power OFF.

Display Sleep Mode:

Quick press the main power button to turn off the LCD display to save energy but keeping the unit ON. Quick press again to wake the LCD display up. After 5 minutes, the LCD automatically goes to sleep while the unit is not in use.

Unit Sleep Mode:

The BASE 5.0 will enter sleep mode after 12 hours if not in use or with loads connected to save battery energy.

1. Selecting 12V DC Outputs: When the unit is powered ON, quick-press either DC buttons on the desired panels to activate the outputs. The left panel outputs Anderson and USB, while the right panel outputs auxiliary car port and 5521 ports.

2. Selecting 230V AC Output: When the unit is powered ON, quick-press the AC button to activate the mains 230V output, the icon will show up on the display and the inverter can be heard activating after a few seconds. Quick-press the AC button again to deactivate mains output.

RECHARGE METHODS

AC Charging

Use the standard AC charging cable to charge the BASE 5.0. Connect as shown in the diagram, the unit will begin charging whether powered ON or OFF, provided the temperature is within the operating range. The maximum charge rate is 2500W, fully charging it from 0% in about 1.5 hours. Slow charging mode can be set to 1250W if desired.

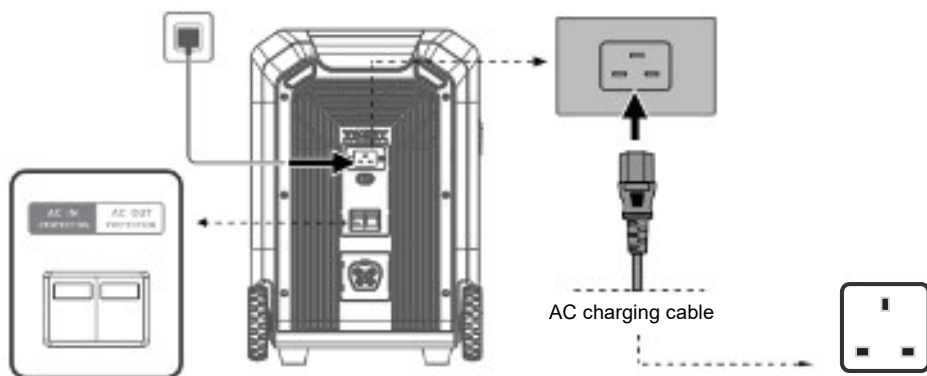

Note: Please use the AC Charging Cable included in the box for charging.

Fast & Slow charge Function:

Note: The unit must be turned ON, and all inputs and outputs must be turned OFF before setting.

1. Press and hold the DC button IOT buttons for 5 seconds until the screen flashes, showing the word "Set". Then tap the IOT button to cycle settings. L means low input (1600W max), H means high input (2500W max).
2. After selecting the desired speed, hold down the POWER button for 3 to 5 seconds to confirm the setting. The screen stops flashing and displays the word "SUC", indicating that the setting change was successful.
3. Exiting the Fast/Slow charge function by pressing and holding the POWER button again for 3-5 seconds.

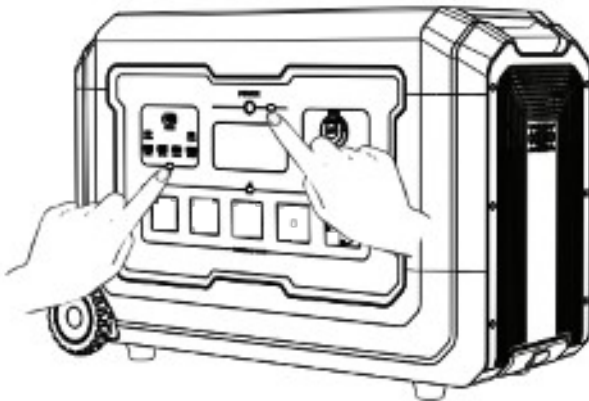

Solar Charge Configuration:

Connect the solar panels to the Anderson input on the side of the unit by using the supplied Anderson to MC4 cable. Multiple solar panels can be connected in series or parallel to achieve the desired input (which should be within the specified 12-150V range). Maximum power input is 2100W, which will charge the unit in one hour.

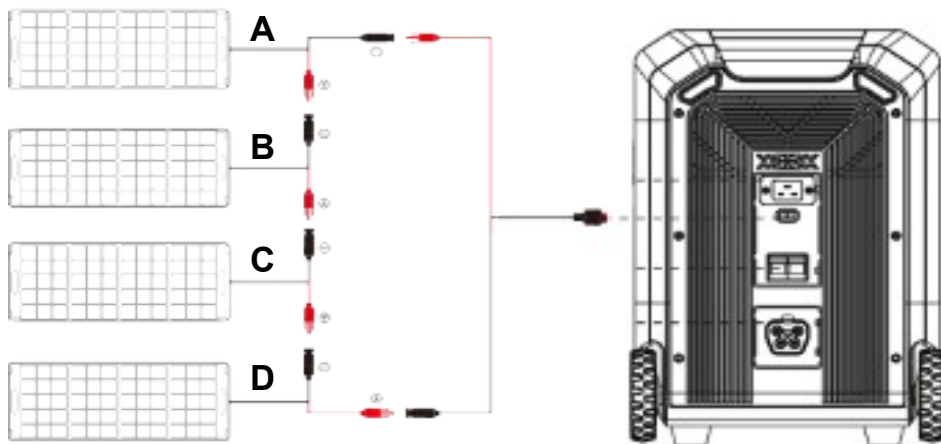

Important: Series wiring combines voltages A, B, C and D. Do not exceed the total Voc limit of 150V or you can damage the MPPT. This can be measured using a voltmeter.

Charging by Vehicle.

Standard Charging:

Use the 12V auxiliary car charger port in your vehicle to charge via the supplied cable. Please start the engine **before** connecting the cable or you can risk running your starter battery flat. Ensure both cable ends are connected properly for and observe the display to confirm the power input (100-120W).

CHARGE-500 Smart Charging:

1. Follow the CHARGE-500 installation setup.
2. Connect the MC4 connectors to the unit via the MC4 to Anderson cable provided (into the solar/Anderson port).
3. Start the vehicle and ensure the CHARGE-500 is ON to receive up to 500W input.

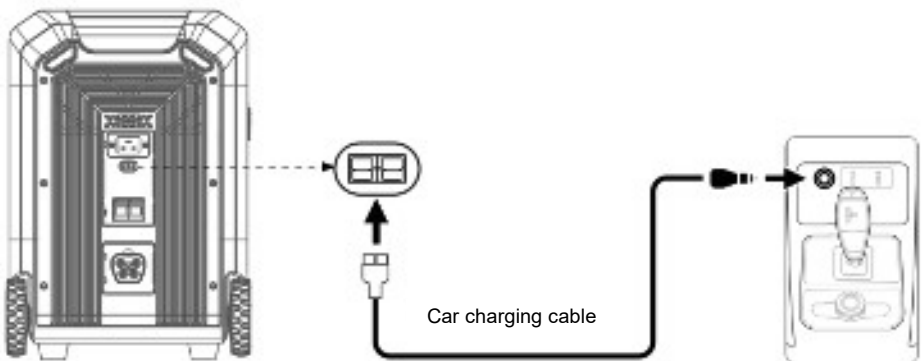

Cascading with Extra Battery Packs (BASE 5.0-EB)

Up to 15 extra battery packs can be connected to the BASE 5.0 by following the instructions below. All linked units will charge in tandem via the host unit from mains AC, vehicle or solar.

BASE 5.0-EB
Extra Battery

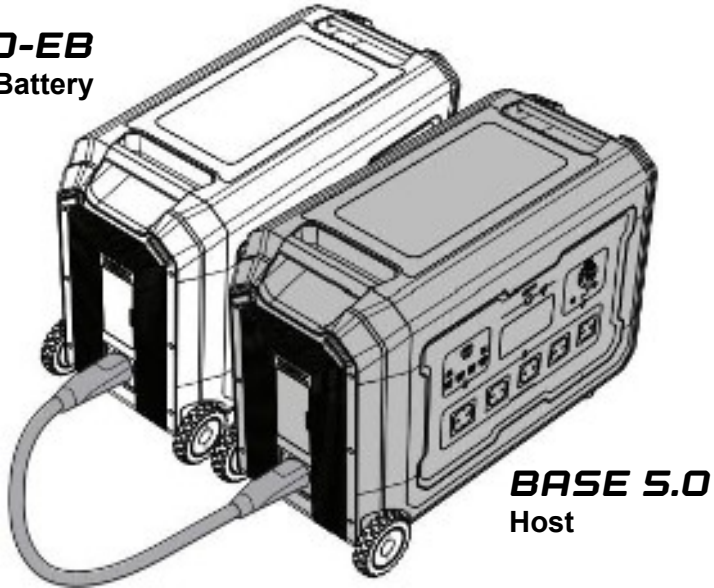

Cascading Procedure:

1. Please make sure that both the BASE 5.0 and any extra batteries are turned OFF before connecting.
2. After the host is connected to all extra batteries, long-press the main power button on any unit to power all units simultaneously.
3. Do not connect or remove any link cables during the charging and discharging process or while units are ON. Always power all units OFF before disconnecting or connecting the link cables.
4. Do not touch or put any conductive items in contact with the cascade ports.

Note: Ensure the ports are covered when not in use and that they do not get dirty. Failure to follow the correct procedures can result in damage to the unit.

OTHER FUNCTIONS

UPS (Uninterruptible Power Supply)

The product supports UPS to <20ms switchover time. When connected to grid power, activate the AC on the unit and use your appliances via the front sockets (AC power will come from the grid and not the BASE 5.0 power unit in this case). In case of a grid failure, the unit will automatically switch to the battery powered AC supply mode within 20 milliseconds.

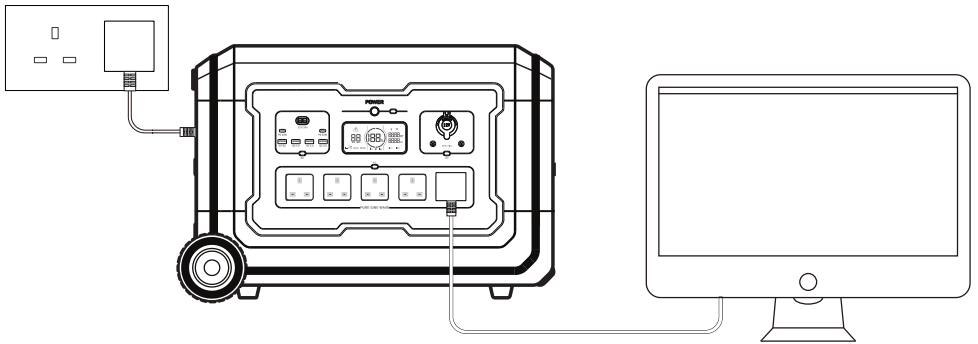

Note:

UPS function is not suitable to specific applications that need a transfer time under 8ms, such as servers and workstations. Please run multiple tests to confirm whether the switchover time is sufficient. It is recommended to use one device only for UPS, with the load of the device not exceeding 5000W. Reaching or breaching the 5000W limit, will result in an automatic AC shut-off for protection. Sherpa Tek Ltd does not accept responsibility for data loss if instructions are not followed correctly.

AC Input and Output Overload Protection

If the AC input current exceeds 16A, the charge input port will be disabled for protection. The AC input overload protector button pops up automatically to cut off the input power. Please check that the power source is not outputting higher than standard mains grid such as in an industrial building or from a motorised generator supply. Also check that the BASE 5.0 is not damaged or faulty before resetting the overload protection trip button.

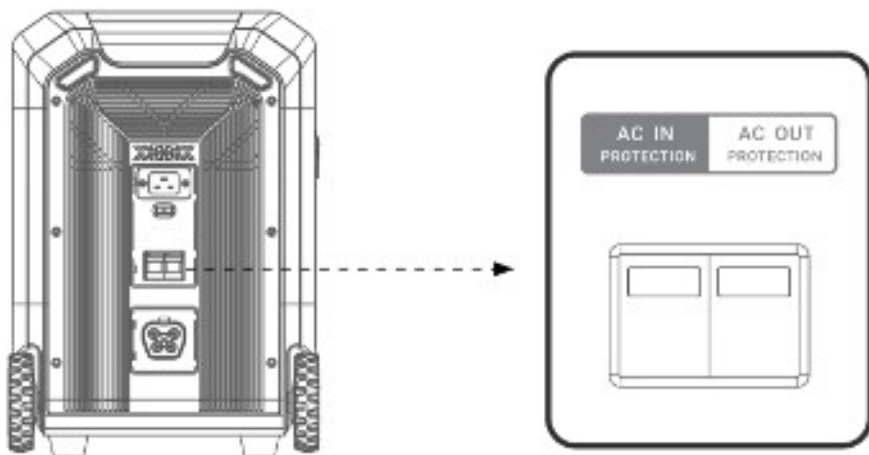

FREQUENTLY ASKED QUESTIONS

Q1. What type of battery does the product use?

A1. It uses high-quality lithium iron phosphate batteries (LiFePO₄).

Q2. What devices can the product's AC output port power?

A2. With 5000W rated power and 7000W peak power, the product's AC output port can power most household appliances. Before use, we recommend that you confirm the power (wattage) of the appliance(s) first and ensure the sum of all loaded appliances is lower than the rated power of 5000W.

Q3. How long can the product charge or run my devices?

A3. The remaining energy time is shown on the product's LCD display, which is more accurate when appliances using a constant power are used.

Q4. How do I know if the product is charging?

A4. The input power is shown in Watts on the LCD display. The circular charging indicator icon rotates to indicate charge activity.

Q5. How do I clean the product?

A5. Wipe it with a dry, soft, clean cloth.

Q6. How to store the product?

A6. Before storing, please charge fully then turn off the BASE 5.0 and store it in a dry, ventilated place at room temperature. Do not place it near water sources. For long-term storage, please discharge and charge it every three months to extend its battery life.

Q7. Can this product be transported by plane?









A7. No, it is classed as dangerous goods and must be shipped by sea and land only.













Q8. Is the actual output capacity of the product consistent with the capacity stated in the user manual?

A8. The capacity indicated in the user manual is the rated capacity of the battery. Since the product has a certain efficiency loss during the charging and discharging process, the actual usable capacity of the product is lower than the capacity specified in the user manual. Approximately 10% of the capacity is reserved to protect the cells also.



FAULT CODES AND TROUBLESHOOTING

Code	Description	Symptom	Trouble Shooting
E000	AC output short circuit protection	  Flashing, no output DC	Press the AC output power ON/OFF button to reset and remove loads
E001	Output overload protection	  Flashing, no output DC	Press the AC output power ON/OFF button to reset and remove loads
E002	AC output unavailable	The AC socket has no output	The unit needs more charge to run AC outputs
E003	AC output high-voltage and low voltage protection	 Flashing, no output	Press the AC output power ON/OFF button to reset and remove loads
E004	Abnormal AC input frequency	 Flashing, no output	Automatically recovers when frequency normalises
E005	High and low bus voltage, over-current	 Flashing, no output	Press the AC output power ON/OFF button to reset and remove loads
E006	<ul style="list-style-type: none"> Inverter over-temperature charging High-temperature protection 	  Flashing, no output DC	Allow the unit to ventilate and cool down before use.
E007	PV input high-voltage and low voltage protection	No solar charging via Anderson port available	Check the Voc of your panel set up using a voltmeter. It will recover automatically when the input voltage meets the input voltage range
E008	12V 30A overload short circuit protection	 Flashing, no output	Remove the load and reset the DC output using the DC ON/OFF button
E009	24V auxiliary power overload short circuit alarm	The DC board reports a fault, but does not turn off the output	Reduce the load on the DC port
E010	Auxiliary car port overload and short circuit	  Flashing, no output DC	Manually press the DC power button to recover and remove the load
E011	USB-A port overload and short circuit	  Flashing, no output DC	Manually press the DC power button to recover and remove the load
E012	USB-C port overload and short circuit	  Flashing, no output DC	Manually press the DC power button to recover and remove the load
E013	Battery low voltage protection during DC discharge	No DC output	The unit needs more charge to run DC outputs

Code	Description	Symptom	Trouble Shooting
E014	PV charging over-temperature	 Solar charging disabled	Allow the unit to cool down before using it again
E015	Anderson 30A output over-temperature	 Flashing, no output	Remove the load and reset the DC output using the DC ON/OFF button.
E020	BMS communication failure	 Flashing, no output	Call support for help
E021	Single cell of the battery has high-voltage	F021 code flashing	Set the device aside and wait for the battery voltage to recover automatically
E022	Single cell of the battery has low-voltage	E022 code flashing	Discharge and charge fully to balance cells
E023	Internal high-voltage	E023 code flashing, unit does not power off	Set the device aside and wait for the battery voltage to recover automatically
E024	Internal low-voltage	 Flashing, no output	Discharge and charge fully to balance cells
E025	Battery cell high-temperature	  Flashing, no output	Allow the unit to cool down before using it again
E026	Battery cell low-temperature	  Flashing, no output	Allow the unit to warm up slowly before using it again
E027	System overload	The AC icon flashes, AC output disabled. DC and AC combined load is higher than 2600W	Manually press the AC power ON/OFF button to reset
E028	Charging high-temperature	  Flashing, device stops input	Allow the unit to cool down before using it again
E029	MOS high-temperature	  Flashing, no output	Allow the unit to cool down before using it again
E030	Incompatible Extra Battery	The Extra Battery or host are not linking	Ensure you are linking either BASE 5.0 or PRO 5.0 to the BASE 5.0-EB

STORAGE AND MAINTENANCE

1. Please store the product away from moisture, in a dry, ventilated place.
2. To prolong the life of the battery, we recommend using or storing this product at temperatures between 20 °C and 30 °C
3. For long-term storage, we recommend discharging the battery to 30% every three months and recharging it to 60% to sustain the battery life. If left discharged for more than 6 months, it may enter deep-discharge and will not be covered under warranty.
4. For safety, do not store this product in extreme temperatures (above 45 °C or below -10 °C) for a long time.
5. Over longer periods, please store the unit horizontally as shown.

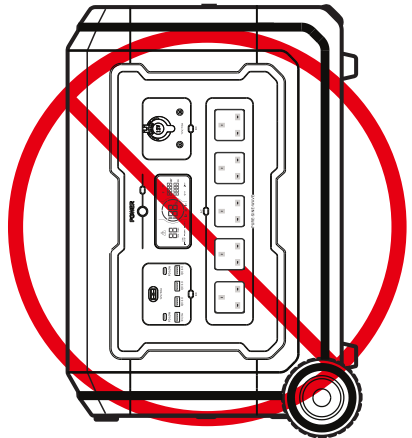
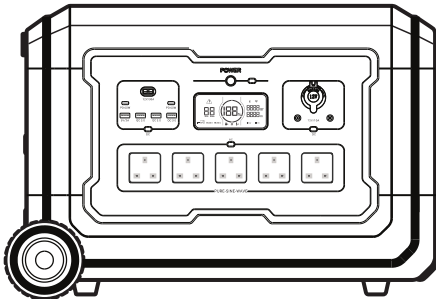

WARRANTY EXCLUSIONS

1. Misused, abused, damaged by accident or damaged due to force majeure (e.g. lightning strikes, hurricane, floods, etc.).
2. Unauthorised modification, repair, dis-assembly or operation not in accordance with the official instructions or manuals.
3. Any defects or damages caused by reliability or compatibility issues when using unauthorised third-party parts.
4. Purchase from unauthorised resellers.
5. Use for special applications other than normal consumer use.
6. Lost, stolen or fully refunded product.
7. Any defect or damage caused by exposure to excessive heat, cold, liquids or other external causes.
8. Invalid proof of purchase.
9. Warranty period expired.
10. The battery model on the warranty certificate does not match the actual item.
11. Unauthorised alteration on the warranty certificate.
12. Product wear and tear from general use.

DISCLAIMER

Read this user manual carefully before using the product to ensure that you completely understand the product and can correctly use it. After reading this user manual, keep it safe for future reference. Improper use of this product may cause serious injury to yourself or others, or cause product damage and property loss. Once you use this product, it is deemed that you understand, approve and accept all the terms and content in this document. Sherpa Tek Ltd is not liable for any loss caused by the user's failure to use this product in compliance with this User Manual.

In compliance with laws and regulations, Sherpa Tek Ltd reserves the right to final interpretation of this document and all documents related to this product. This document is subject to changes updates, revisions, or termination) without prior notice. Please visit the official website to obtain the latest product information.

Please read our warranty exclusions on Page 18 for our terms and conditions.

DISPOSAL

1. When conditions permit, please be sure to completely discharge the battery of this product, and then put the product in the designated battery recycling box. This product contains batteries which contain dangerous chemicals and are strictly prohibited from being disposed of in general waste. For details, please follow local laws and regulations on battery recycling and disposal.
2. If the battery cannot be completely discharged due to the failure of the product itself, please do not dispose of the battery directly in the battery recycling box, and contact a professional battery recycling company for further advice.
3. The battery can enter a deep discharge state if left to drain over a long period and will no longer be able to accept charge, please dispose of it according to current waste regulations.

CUSTOMER SUPPORT : support@sherpapower.co.uk

www.sherpapower.co.uk

Sherpa Tek Ltd.



Own Your Energy