



BOBIL VANS INTERNAL TANK BACKFILL KIT

INSTALLATION INSTRUCTIONS





What comes in the box?

Thank you for purchasing this plumbing kit! In this kit you will receive everything you need to fill your internal tank from the outside of your vehicle and run this piping up to the inlet of the filter of your diaphragm pump. All the connectors and joiner pieces fit 12mm John Guest Pushfit pipe unless otherwise specified.

This kit also assumes that the internal tank does not have any sort of breather valve and is just a sealed tank. If yours already has a breather/overflow pipe installed, then you do not need to install the one that comes in the kit. Any internal tank can be used, but we have used wheel arch tanks for this install guide.

Kit Contents

- 1 x Bulkhead Connector
- 1 x 12mm John Guest Stem Elbow
- 4 x 12mm Elbows
- 1 x ½" Male Fitting
- 1 x ½" Female Fitting
- 1 X 12mm Tee
- 1 x Backfill Plate, Integral Bolts, Valve, Hoselock Fitting, 15-12mm Stem Reducer
- 2 x Floor Grommets
- 1 Roll PTFE
- 2m of Blue 12mm JG Pipe
- 2 Bolts

Thank you for buying our products!

Small businesses like ours only exist because of the support of our customers. We appreciate you purchasing from us, and hope that you have a great experience.

If you have any installation questions or queries then just get in touch, we're here to help. Contact us at info@bobilvans.co.uk or on the phone at +44 1275 261074



Installation

1. **BREATHER INSTALL:** Install the breather into the tank. If the breather/overflow is not fitted, the tank will pressurise when filling and when it is full, will flood your van so this **must be installed!**

Drill a 26mm-28mm hole in the top of the tank, remove the nut from the bulkhead fitting, place the fitting through the hole and secure with the nut from underneath.

Push the stem elbow into the top of the bulkhead fitting to give a right-angled outlet and attach the elbow and blue pipe as shown. This pipe can be directed out the van with the supplied grommet.

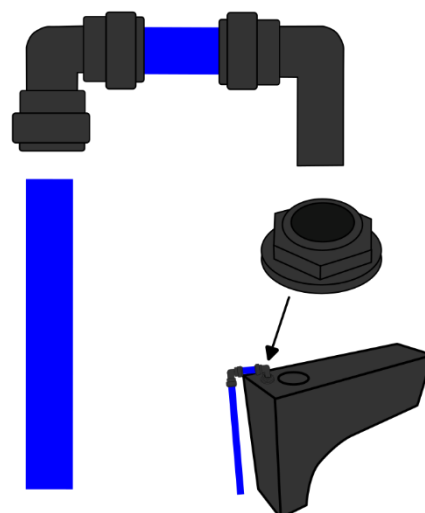

2. **TANK OUTLET:** Next, assemble the tank outlet. Check that the tank's threaded hole has been drilled out first, as not all of them are. Wrap PTFE round the thread on the 1/2" male fitting, and screw it into the tank.

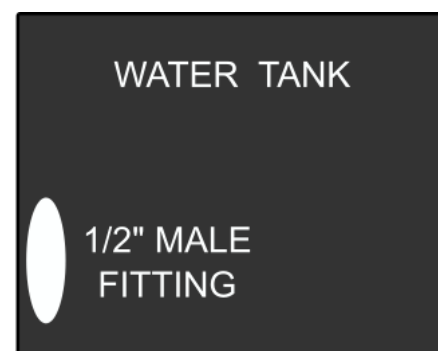
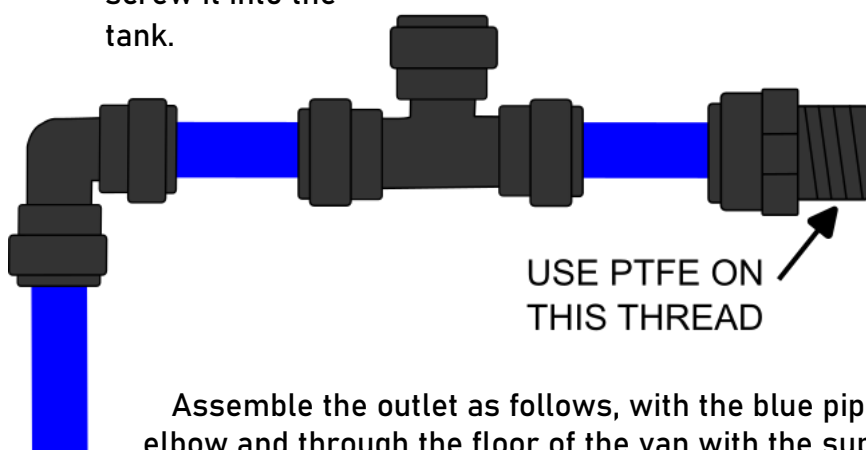

Assemble the outlet as follows, with the blue pipe going into the T, through the elbow and through the floor of the van with the supplied grommet.

3. **BACKFILL INSTALL:** Cut the hose going through the floor of the van to the right length and attach the remaining elbow. Run this towards the backfill point which you can attach to the van sill with bolts by drilling 2 x 5.5mm holes at a hole pitch of 44mm. We recommend recessing it from the sill, and facing the hose lock connector backwards to avoid it getting covered in road debris.

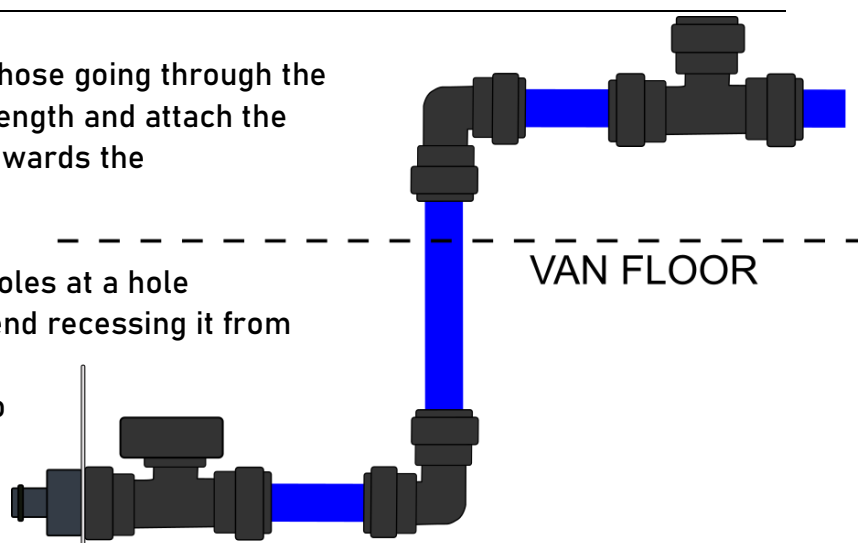



4. **CONNECT TO PUMP:** Then you can run the middle outlet of the tee off to the diaphragm pump using the remaining elbow and ½" female JG fitting.

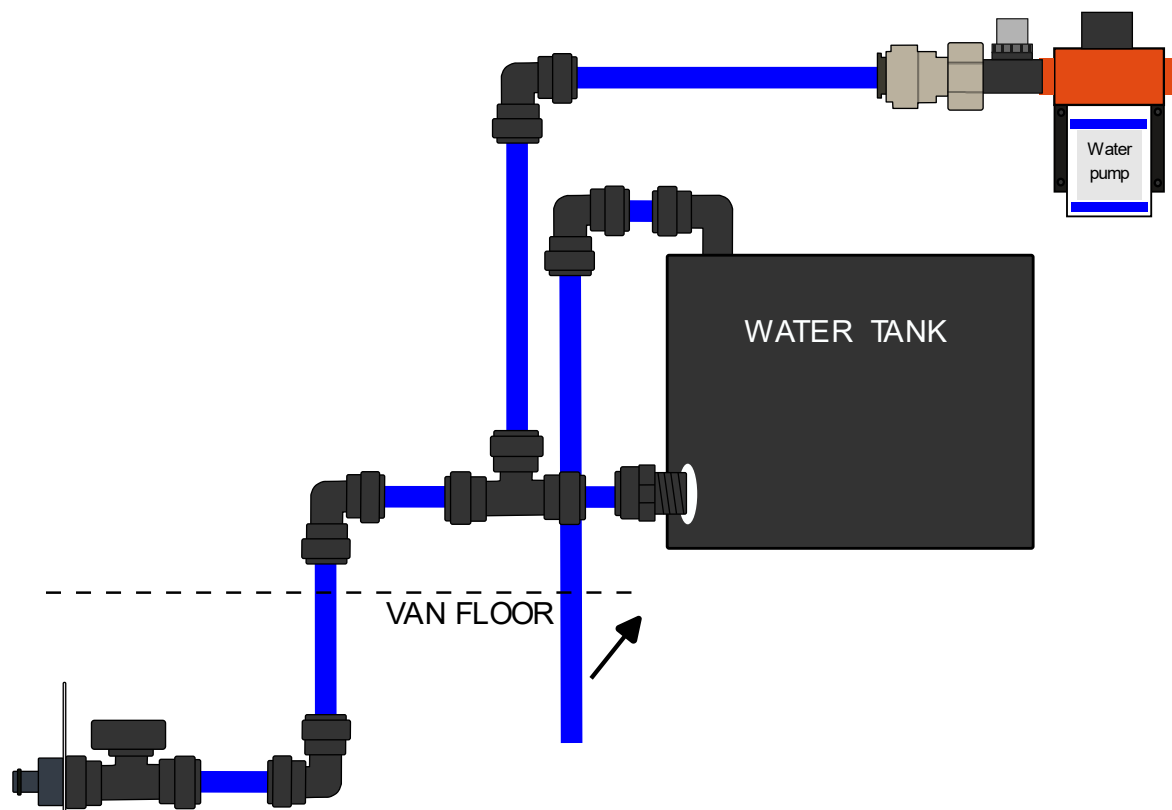

We would love to know what you think! Please let us know by leaving a review through the link sent through when you made your purchase, or email us at info@bobilvans.co.uk!

www.bobilvans.co.uk

@bobilvans



©2024 Bobil Vans Ltd

Registered in England. Company no: 13307438.
VAT reg no: 376 3711 79.